



Ergonomic Handling Systems



Global Solution Centers

Providing turnkey, customized solutions that improve our customers' productivity and efficiency:

Custom Ergonomic Handling Systems



Custom Multi-Spindle Fastening Systems

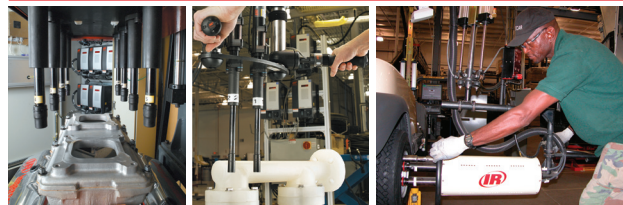

Custom Solution Process

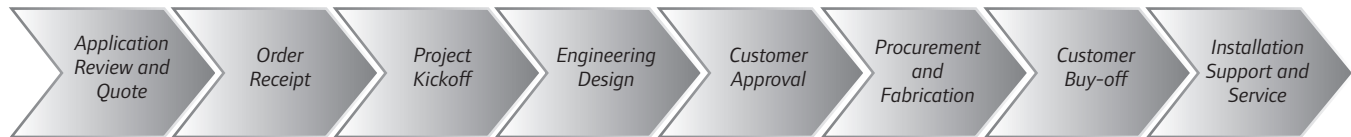

From RFQ

To Installation

Offering full-service capabilities tailored to our customers' needs:

Engineering

- ▶ Feasibility study
- ▶ Concept design
- ▶ Simulation
- ▶ System design
- ▶ 2D and 3D CAD

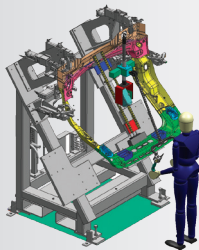

Service

- ▶ Installation and start-up support
- ▶ Training
- ▶ Preventive maintenance
- ▶ Calibration and repair service
- ▶ Technical support



Project management

- ▶ Dedicated project manager
- ▶ Project planning
- ▶ Coordination
- ▶ Execution

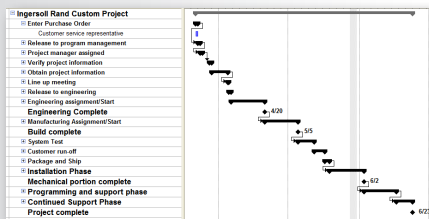

Served industries include:

- ▶ Aerospace
- ▶ Appliance
- ▶ Automotive
- ▶ Defense / military
- ▶ Electronics
- ▶ Food and beverage
- ▶ Furniture
- ▶ Heavy equipment
- ▶ Marine
- ▶ Medical

France

Ingersoll Rand Company
70, rue Jacquard
77400 Lagny sur Marne, France
Telephone: +33 1 64 76 00 00

North America

Ingersoll Rand Company
1872 Enterprise Drive
Rochester Hills, MI 48309, USA
Telephone: +1 (248) 293-5700

Mexico

Ingersoll Rand, S.A. de C.V.
Boulevard Centro Industrial No. 11
Industrial Puente de Vigas
54070 Tlalnepanitla, Mexico
Telephone: +52 (55) 50056600

India

Ingersoll Rand Industrial Products Pvt. Ltd.
37-A, Site 4, Sahibabad Industrial Area
Ghaziabad-201010, India
Telephone: +91-120-4389400 / 4289400

China

Ingersoll Rand Company
335 Lv Chun Road
Minhang Industrial Zone
Shanghai 200245, P.R.C.
Telephone: +86.21.6463.8018

Russia

ZAO Ingersoll Rand CIS (1043)
Pavlovo Factory Ul. Chapaeva 43
Nizhegorodskaya Oblast
Pavlovo 606108
Russian Federation
Telephone: +7 (83171) 3 22 22



Contents

er·go·nom·ics (ûr'guh-nôm'iks)

n.

1. The applied science of equipment design, as for the workplace, intended to maximize productivity by reducing operator fatigue and discomfort.
2. Design factors, as for the workplace, intended to maximize productivity by minimizing operator fatigue and discomfort.

See also: *Ingersoll Rand*

Since 1959, Ingersoll Rand has been at the forefront of developing ergonomic solutions for lifting, manipulating, and transferring loads by offering a complete line of products designed to maximize productivity while simultaneously minimizing operator fatigue and discomfort. No matter what your requirement, Ingersoll Rand offers the products for you to do your job effectively, efficiently, and above all, safely. By choosing Ingersoll Rand, you are receiving 50 years of innovation and product expertise that is unrivalled anywhere else.

Rail Systems

6



Arm Systems

31

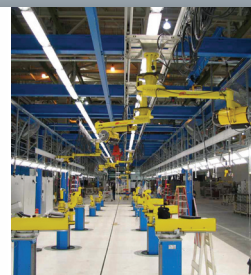

Jib Cranes

12



Hoists

39



Balancers

19











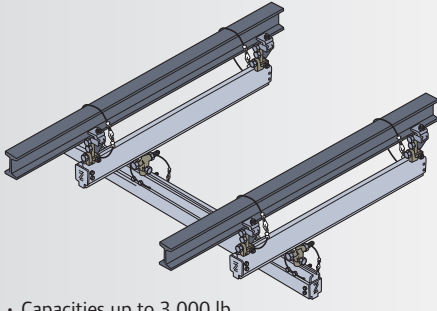

Handling Devices

44



Three Building Blocks to a Complete Ergonomic Handling Solution

OVERHEAD SUPPORT			
Rail System (pg 6)			
Freestanding Workstation Crane (pg 7)	Ceiling-Supported Workstation Crane (pg 7)	Monorail (pg 7)	
 <ul style="list-style-type: none"> • Capacities up to 2,000 lb • Floor supported to eliminate the need for overhead support structure • For use when there is adequate floor space and /or the ceiling structure cannot support the load • Provides rectangular coverage for a single workstation, or an entire assembly line with multiple bridge cranes 	 <ul style="list-style-type: none"> • Capacities up to 3,000 lb • For use when there is limited floor space and adequate ceiling structure to support the load • Capable of mounting parallel or perpendicular to overhead support steel • Provides rectangular coverage for a single workstation, or an entire assembly line with multiple bridge cranes 	 <ul style="list-style-type: none"> • Provides simple single-axis transfer • Curved sections available for navigating obstructions 	
 <p>TRANSFER</p>			
LIFTING / BALANCING DEVICE			
Pneumatic Balancer (pg 20)	IntelLIFT® Balancer (pg 24)	Spring Balancer (pg 28)	
 <ul style="list-style-type: none"> • Capacities up to 2,000 lb • Allows user to move load via up / down controls then float mode allows for precision manual movement and placement of the load without having the “jogging” associated with air and electric hoists • Energy savings — less air consumption than an air hoist • Used in applications where precision spotting is necessary • Offers up to 120" travel 	 <ul style="list-style-type: none"> • Capacities up to 1,000 lb • IntelLIFT removes the need for up / down switches and allows for completely manual operation by sensing user force input and translating it to precise lifting / lowering • Features float mode throughout entire range of motion • Used in applications where: <ul style="list-style-type: none"> - Precision spotting is necessary - Hands-on control of load is required / beneficial - One hand operation is beneficial 	 <ul style="list-style-type: none"> • Capacities up to 363 lb • Lifts ranging from 5 to 9 ft • Used in applications where: <ul style="list-style-type: none"> - Loads travel a relatively short distance - One tool is used repeatedly in a limited area of motion, such as assembly stations - Single load balancing is required (weld guns, assembly fixtures, etc.) 	
 <p>LIFT / LOWER / BALANCE</p>			
HANDLING DEVICE			
Hook (pg 48)	Probe (pg 47)	Trap (pg 48)	
 <ul style="list-style-type: none"> • Used in applications where: <ul style="list-style-type: none"> - Simple pick and place - Straight transfer with no part manipulation - Hook access is readily available - Odd-shaped parts 	 <ul style="list-style-type: none"> • Used in applications where: <ul style="list-style-type: none"> - Part is cylindrical with an accessible hole in the core - Straight transfer or manipulation of parts - Typical parts include rolls and machined parts 	 <ul style="list-style-type: none"> • Used in applications where: <ul style="list-style-type: none"> - Simple pick and place - Straight transfer with no part manipulation - Accessible grab locations on both sides of part 	
 <p>GRIP / MANIPULATE</p>			

OVERHEAD SUPPORT

Jib Crane (pg 12)

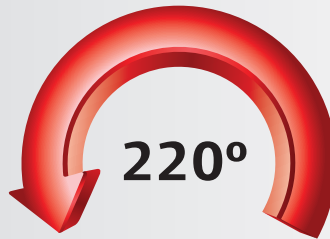
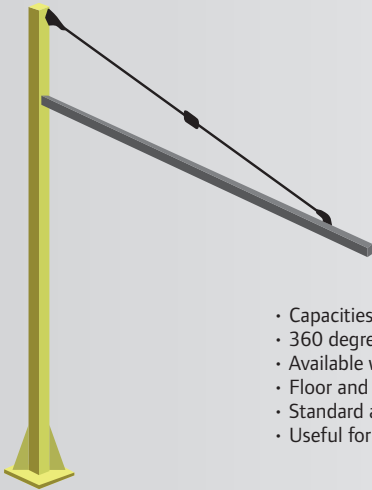

- Capacities up to 2,000 lb
- 360 degrees of circular coverage area
- Available with up to 14 ft (12 ft standard) boom underclearance
- Floor and wall mounting options
- Standard and low profile configurations
- Useful for short transfer applications less than 20 ft

LIFTING / BALANCING DEVICE

Arm (pg 31)

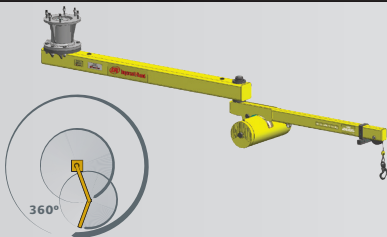

- Capacities up to 1,000 lb
- Great for reaching in, under, and around obstacles to precisely and effortlessly position loads
- Column or overhead mounting options
- Available in three styles: articulating, parallel link, and vertical mast
- Up to 10 ft of horizontal reach

Torque Tube (pg 49)



- Capacities up to 150 lb
- Vertical travel range of up to 36 inches
- Rigidity of the system minimizes inertia when moving loads into place along a rail system
- Useful with lifting offset loads where the weight of the load is disproportionate to the center of gravity
- Provides torque reaction for fastening systems

Air / Electric Hoist (pg 42 & 40)



Air

- Capacities up to 2,200 lb
- Very durable
- Continuous duty cycle
- Allows for “jogging” of load — movement up / down at various speeds
- Easy to maintain



Electric

- Capacities up to 2,200 lb
- Single or dual speed available
- Offers quiet, clean operation as there’s no need for oil or air

HANDLING DEVICE

Vacuum (pg 45)

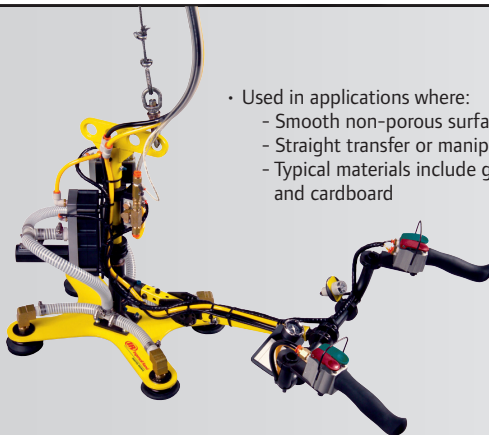

- Used in applications where:
 - Smooth non-porous surface is available
 - Straight transfer or manipulation of parts
 - Typical materials include glass, sheet metal and cardboard

Clamp (pg 46)

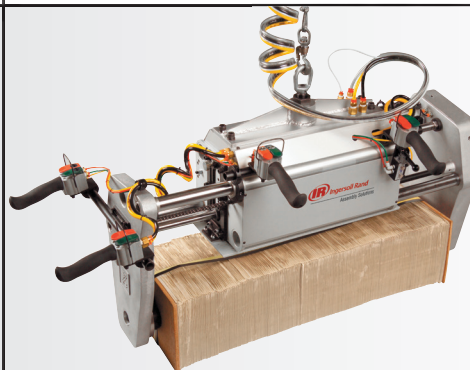

- Used in applications where:
 - Part is rigid with accessible clamping surfaces
 - Straight transfer or manipulation of parts
 - Typical parts include machined parts, bundles, fabricated metal parts

Rail Systems

The backbone of any ergonomic material handling system

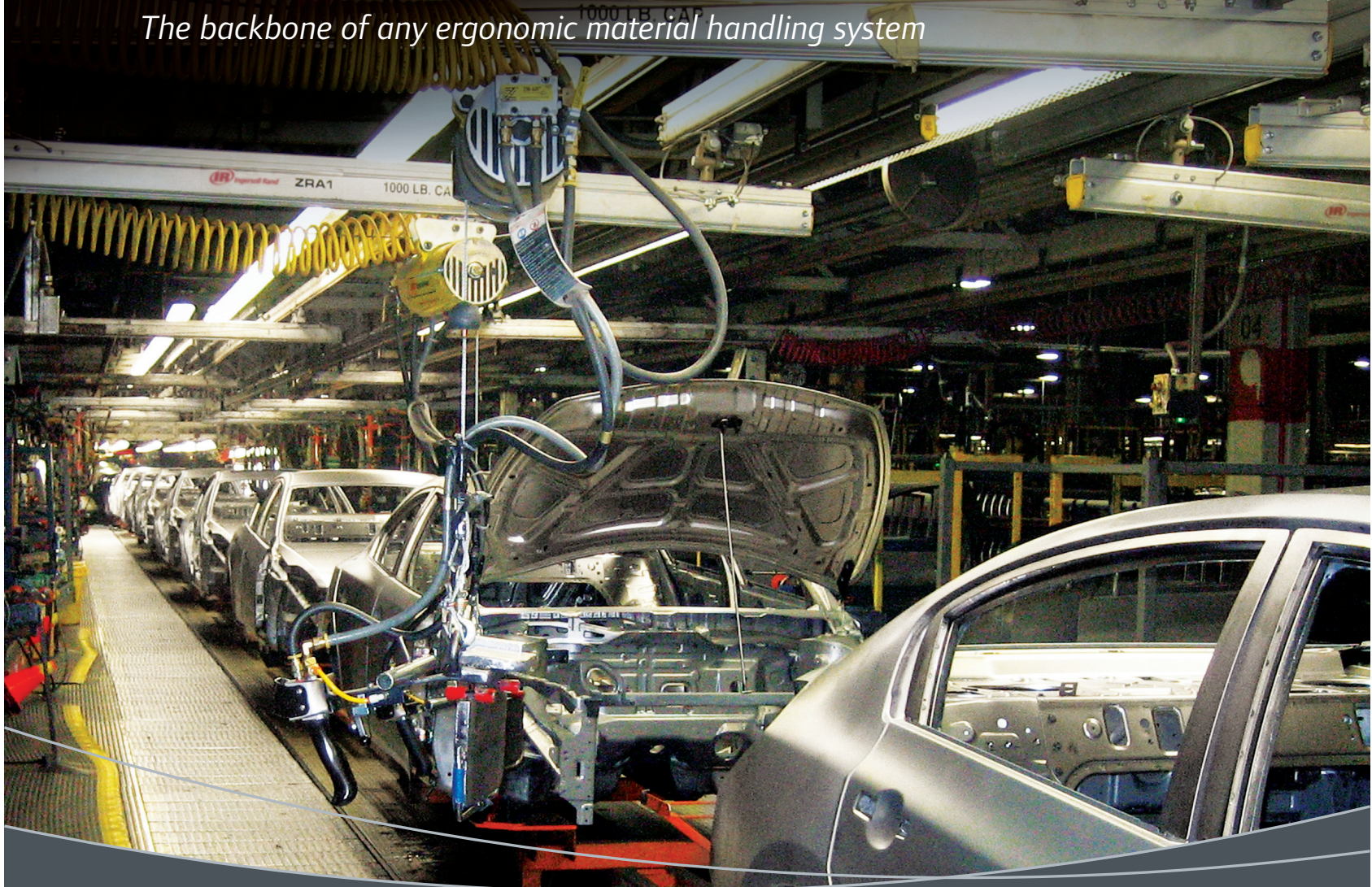

Ingersoll Rand offers:

- ▶ Ceiling-supported workstation bridge cranes
- ▶ Freestanding workstation bridge cranes
- ▶ Monorails

MMA-CERTIFIEDSM

MONORAIL Manufacturers[®]
Association

Workstation Cranes & Patented Track Systems

Meets or Exceeds ANSI MH27.1 or MH27.2

To review compliance requirements and confirm certification, visit www.mmacertified.org

Ingersoll Rand Rail Systems are now MMA-Certified.

Zimmerman Series Rail Systems

Ceiling-supported workstation bridge cranes:

- ▶ Ideal for high-volume production environments with limited floor space
- ▶ Capable of mounting parallel or perpendicular to overhead support steel
- ▶ Provide rectangular coverage for a single workstation, or an entire assembly line with multiple bridge cranes
- ▶ Capacities up to 3,000 lb

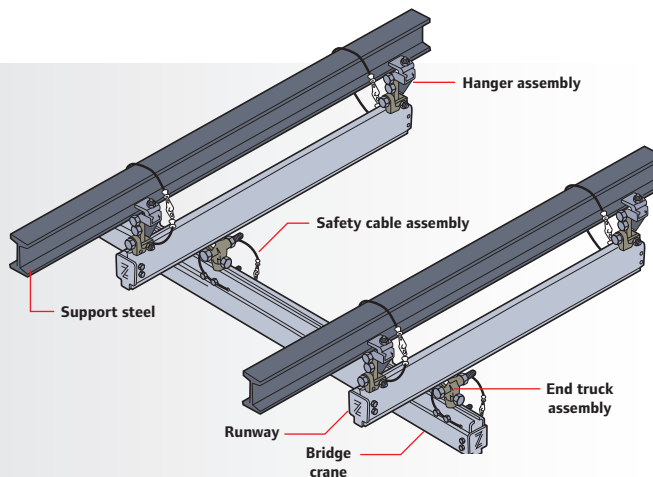

Freestanding workstation bridge cranes:

- ▶ Floor supported to eliminate the need for overhead support structure
- ▶ Available in 1/4, 1/2, and 1 ton capacities and 4, 6, 8, 10, and 12 column designs to cover lengths up to 105 ft or more
- ▶ Lindapter® adjustable toe clamps make it simple to align runways for smooth operation
- ▶ Rugged design with gusseted column base plates

- ▶ Custom-designed structures available to meet special applications

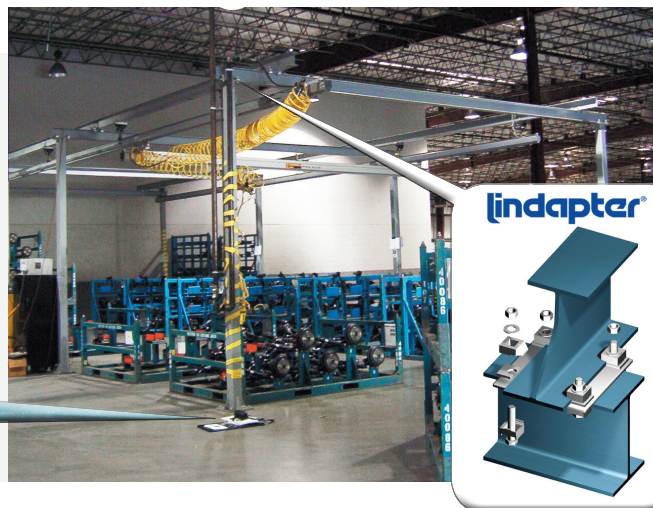
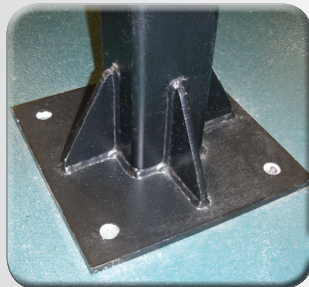

Monorails:

- ▶ Provide simple single-axis transfer
- ▶ Curved sections available for navigating obstructions



ZRA1		ZRS2	
36"	15°	60"	10°
36"	30°	60"	15°
36"	45°	60"	30°
36"	60°	60"	45°
36"	90°	60"	60°
		60"	90°



Zimmerman Series Rail Systems

Profiles:

Quality steel, aluminum, and stainless steel rail systems
 Ingersoll Rand rails are available in three different materials and five different sizes to meet your specific material handling needs. The enclosed rail systems design reduces the accumulation of dirt and grime on the internal rolling surfaces, thus reducing rolling effort.

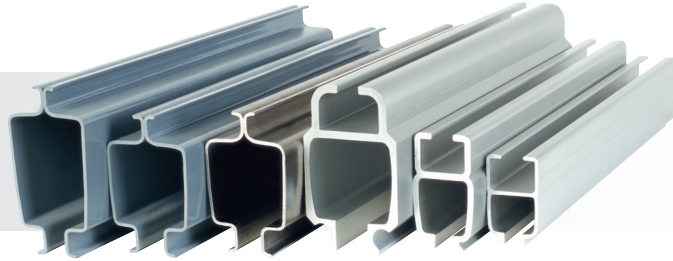

The Ingersoll Rand Rail Systems **ADVANTAGE**

- ▶ **Lightweight and ergonomic** — Less than 1 percent rolling resistance
- ▶ **Precision running surface** — Aluminum, steel, and stainless steel available
- ▶ **Modular and flexible** — Bolted together; no welding required
- ▶ **Clean, maintenance-free operation** — No lubrication required
- ▶ **Safety** — Designed to meet or exceed all national and international standards
- ▶ **Now MMA Certified** — Certified by the Monorail Manufacturers Association to meet or exceed ANSI MH27.2 monorails and underhung cranes



Lightweight aluminum profiles

- ▶ Lightweight and available for long spans
- ▶ Extruded from aluminum alloy 6063-T6
- ▶ Clear anodized for a smooth, clean, corrosive-free surface

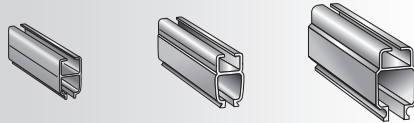

ZRAT

ZRA1

ZRA2

Rugged steel profiles

- ▶ Roll formed from 9 gauge, A569 hot-rolled steel
- ▶ Spot welded with automated welder for maximum strength
- ▶ Powder-coat painted for durability and smoothness

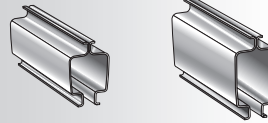

ZRS2

ZRS3

Clean stainless steel

- ▶ Engineered for clean room applications
- ▶ Ideal for the food and pharmaceutical industries
- ▶ Roll formed from 10 gauge, 316 L stainless steel

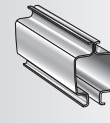

ZRSS

Part No.	31000		30200		30000		30500		30550		30500S	
	lb	kg	lb	kg	lb	kg	lb	kg	lb	kg	lb	kg
Weight per Foot	lb	2.15	4.10	7.60	8.00	8.90	8.86					
	kg	0.97	1.86	3.45	3.60	4.00	4.01					
Vertical Height	in	3.83	4.90	7.00	5.91	7.13	5.91					
	mm	97	124	177	150	181	150					
Maximum Length	ft	24	30	30	24	24	16					
	m	7	9	9	7	7	5					

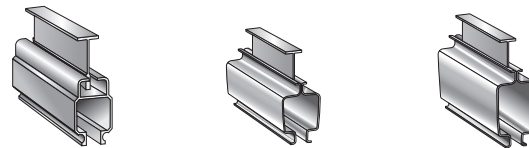

ZRA2T

ZRS2T

ZRS3T

Strongback profiles

- ▶ Reinforced profiles for added strength
- ▶ Uses the same hardware as standard profiles
- ▶ Increases span capacity

Part No.	30000T		30500T		30550T	
	lb	kg	lb	kg	lb	kg
Weight per Foot	lb	14.96	11.62	12.52		
	kg	6.78	5.27	5.68		
Vertical Height	in	13.0	7.83	9.20		
	mm	330.0	198.8	233.6		
Maximum Length	ft	30	24	24		
	m	9	7	7		

Zimmerman Series Rail Systems

Components:

Safety first

The primary and vital concern of Ingersoll Rand is *safety*.

- ▶ **Deflection** — Ingersoll Rand rail is designed to not exceed 1/450 of span, in accordance with ANSI B30.11 monorail and underhung cranes
- ▶ **Safety cables** — We require the use of safety cables at all moving (hanger and end-truck) suspension points
- ▶ **Redundant end stops** — Available for extra safety
- ▶ **Load ratings** — Clearly marked on both sides of bridge cranes
- ▶ **Safety factor** — All hardware components are rated at a 5 to 1 safety factor based on meticulous tests performed at independent testing laboratories

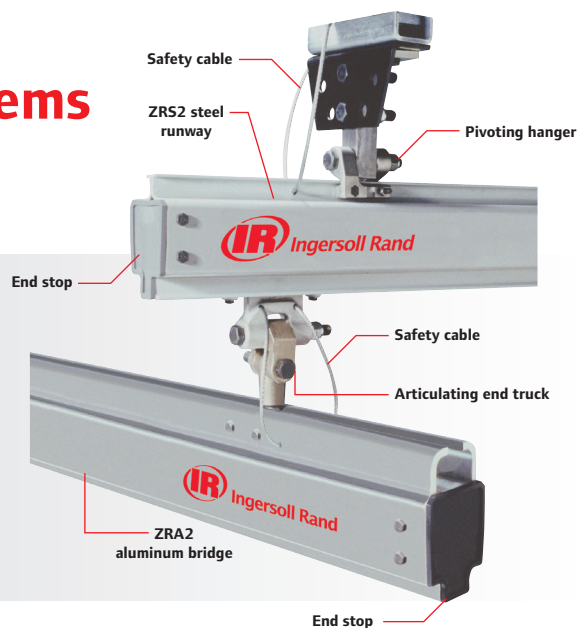

Hangers

- ▶ Attach to I-beam, angle iron, C-channel, and other overhead steel shapes
- ▶ Close and rigid style hangers available for low headroom
- ▶ Adjustable-height hangers provide easy leveling
- ▶ Sway bracing for hanger drops >24" for added safety and stability

Articulating end trucks

- ▶ Maximize the ability of the operator to precisely position the load
- ▶ Reduce fatigue by allowing the operator to move only the portion of the bridge crane near the load
- ▶ Dramatic improvements over typical rigid end-truck systems, which require the user to move the entire mass of the bridge crane for each operation

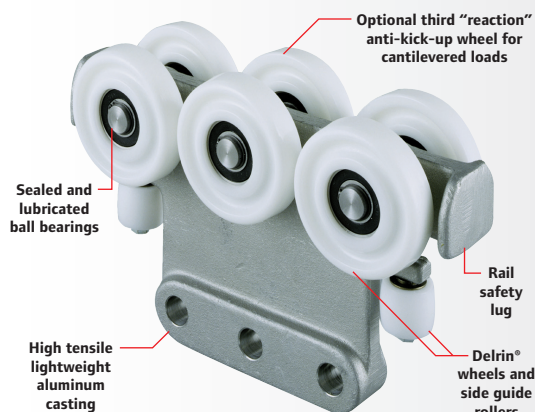

Advanced trolley design

Ingersoll Rand trolleys are designed to work in conjunction with the enclosed track rail to reduce the rolling effort required to move a load. In fact, only a force equal to 1 percent of the total rolling weight is needed when moving loads.

- ▶ **Lightweight** — Trolleys are made from high-strength, lightweight aluminum castings
- ▶ **Injection molded wheels** — Provide for clean, wear-free operation that resists flattening
- ▶ **Sealed precision bearings** — In wheels and side guide rollers, they provide long life and reduced maintenance
- ▶ **Rail safety lug** — Prevents the body of the trolley from being pulled through the enclosed track rail
- ▶ **Versatile** — Ingersoll Rand-built trolleys are available for use in virtually every manufacturer's enclosed track rail system

Zimmerman Series Rail Systems

Accessories:

Power supply

Air supply kits:

- ▶ Available in both 3/8" and 1/2" to fit application needs
- ▶ Includes filter regulator to ensure clean regulated air supply
- ▶ Provides complete utilization of the bridge and runway system

Electrical supply kits:

- ▶ Available with or without flat conductor cable
- ▶ Secured to rail system eliminating interference with operator

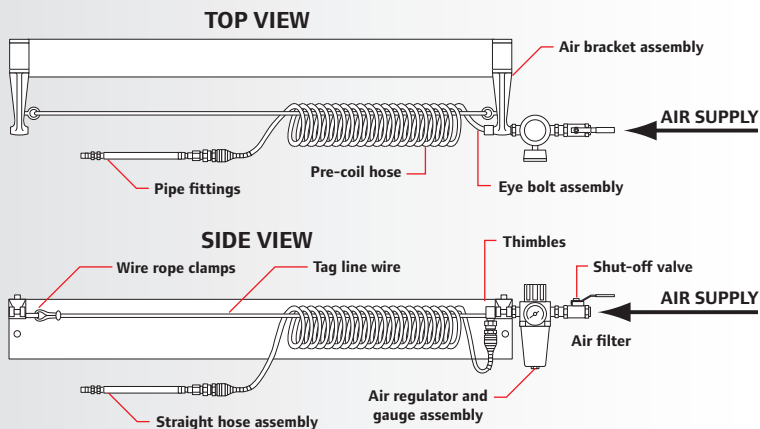

Additional accessories:

Assorted load trolleys



Hoist trolley



Balancer suspension

Bumper trolley

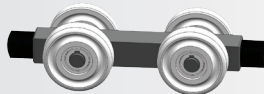

- ▶ Safely separate multiple bridge cranes

Adjustable stop

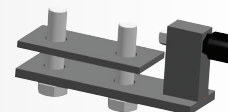

- ▶ Easily adjust travel limit of bridge crane or load trolley

Inspection gates

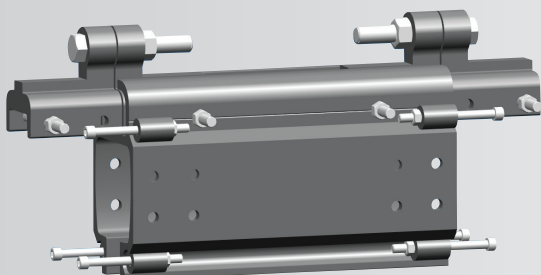

- ▶ Provide simple inspection of trolleys and end trucks

Insul-8™ electrification

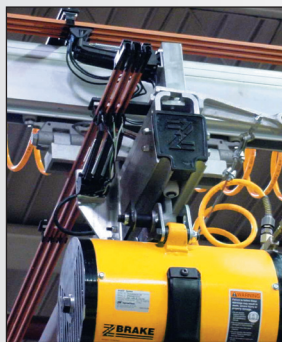

- ▶ Clean electrification for long runs

Festooning trolleys



- ▶ Strap style
- ▶ Stamped
- ▶ Flat cable slider

Also available:

- ▶ Dual bridge kits for carriage applications
- ▶ Bridge extensions for reaching inside machines

Ingersoll Rand offers a full line of accessories to configure rail systems to your specific application

Zimmerman Series Rail Systems

Additional resources:

The Assembly Configuration Engine (ACE)

ACE is extremely flexible, enabling you to quote projects in a variety of ways. You can use ACE as a simple, guided selling tool to automatically configure systems based on relatively few inputs, or you can put it to use as a fully customized system with multiple options that you pick and choose.

Quoting with the tool is simply a matter of selecting the type of rail system(s) needed, entering customer requirements, choosing accessories and parts, then inputting customer information for the proposal.

It's as easy as:

- 1 Select
- 2 Configure
- 3 Quote

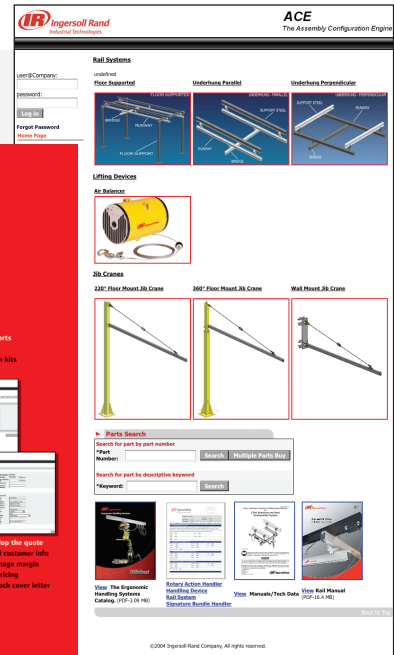

Available to authorized Ingersoll Rand distributors at: irtools.com/ACE

Rail Systems technical reference

Item No.	Part No.	Description	Qty
1	29587	Lock Nut, S.B. - 11	2
2	2952446	S/B - 11 x 2.57" 1/8" Grade 5	2
3	29587-02	Safety Cable Assembly (Close to line shavers)	1
4	30285	Hanger Kit, Z8AT, Block, Perpendicular	1
5	30187	Hanger Kit, Wide Flange Beam	1

- ▶ Detailed specifications
- ▶ Load charts
- ▶ Dimensional info

Available at: irtechpubs.com
(Doc. #16598542)

Drawings and CAD files available on the Web

Hangers

For ease of installation, we offer a wide variety of fully assembled hangers to attach to virtually any type of overhead steel including I-beams up to 120" wide. They can be installed perpendicular or parallel to the overhead steel and require a set internal to achieve runway capacity. One safety cable is required per hanger and one hanger is required within 1' foot of each end or splice. Available in either rigid or pivoting styles to match the material handling operation, the hangers are available in fixed or adjustable lengths up to 72" or longer. For extra safety, we require that all hangers with a drop of 24" or greater have cross bracing for stability.

Features

- Safety
- All hardware rated at 5:1 safety ratio
- Safety cables
- Safety cables at each hanging point
- Cross brace kits

- ▶ 2D drawings
- ▶ 3D solid models
- ▶ Great for plant layouts

Available at: irtools.com/lifting

Jib Cranes

Solutions for compact workstations

Ingersoll Rand offers:

- ▶ 220° or 360° rotation
- ▶ Floor or wall mount
- ▶ Standard or low profile
- ▶ Capacities to 2,000 lb

Zimmerman Series Jib Cranes

The Ingersoll Rand Jib Crane **ADVANTAGE**

- ▶ **Ergonomic** — Unique single contact point, tapered roller bearing design provides easiest rotation in the industry on 360 degree jib cranes
- ▶ **Precision** — Made from precision Ingersoll Rand aluminum or steel rail, resulting in a lightweight, easy-to-move boom with low rolling resistance for smooth travel
- ▶ **Cost Effective** — Jib cranes are an inexpensive solution for short transfer applications
- ▶ **Rugged Reliability** — Light, Medium, and Heavy Duty configurations to meet every application

How to select

Rotation

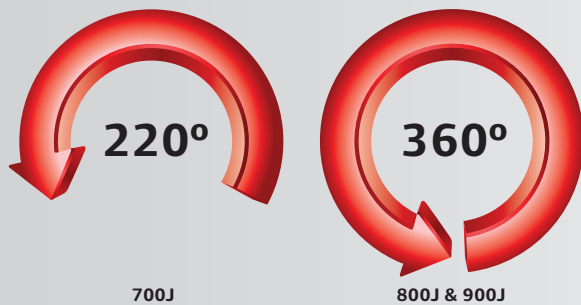

Capacity

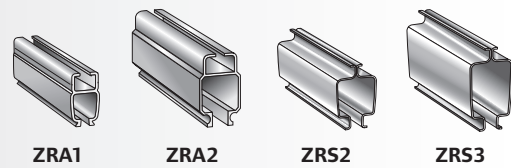

Jib Style	lb (kg)	lb (kg)	lb (kg)	lb (kg)
700J	900 (408.2)	2,000 (907.2)	2,000 (907.2)	2,000 (907.2)
800J*	820 (371.9)	820 (371.9)	820 (371.9)	
900J*		820 (371.9)		

Note: Jib styles marked with a * are available in floor-mount configuration only

Boom length

- ▶ Radius of coverage area
- ▶ Most ergonomic operation is closer to end of boom

Boom underclearance

- ▶ Distance from floor to bottom of boom
- ▶ Available up to 14 ft (4.27 m) (12 ft [3.65 m] standard)

Overall height

- ▶ Distance from floor to top of jib crane
- ▶ 900J Series offers lowest overall height

Boom profile

- ▶ Clean, lightweight anodized aluminum (ZRA1 and ZRA2)
- ▶ Rugged powder-coated steel (ZRS2 and ZRS3)

NOTE: For proper installation of a floor-supported jib crane system a minimum of a 6" (15.2 cm) thick reinforced concrete floor is required. Consult a registered structural engineer before installing the jib crane. This is required to ensure local building codes, possible seismic loading considerations and variance in concrete slab and soil conditions are addressed.

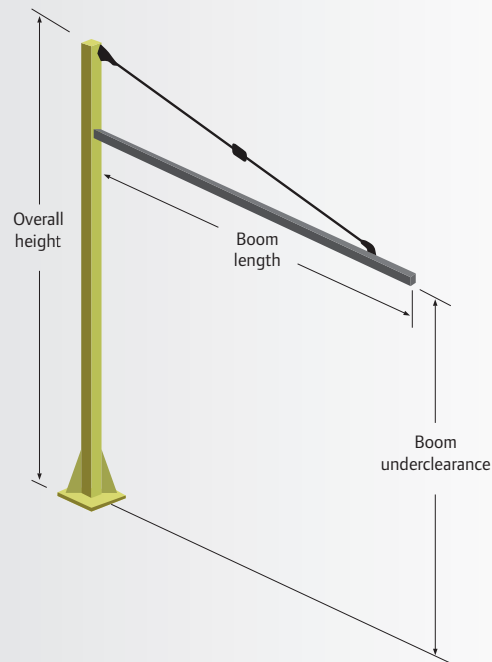

Zimmerman Series Jib Cranes

800J (360 degree):

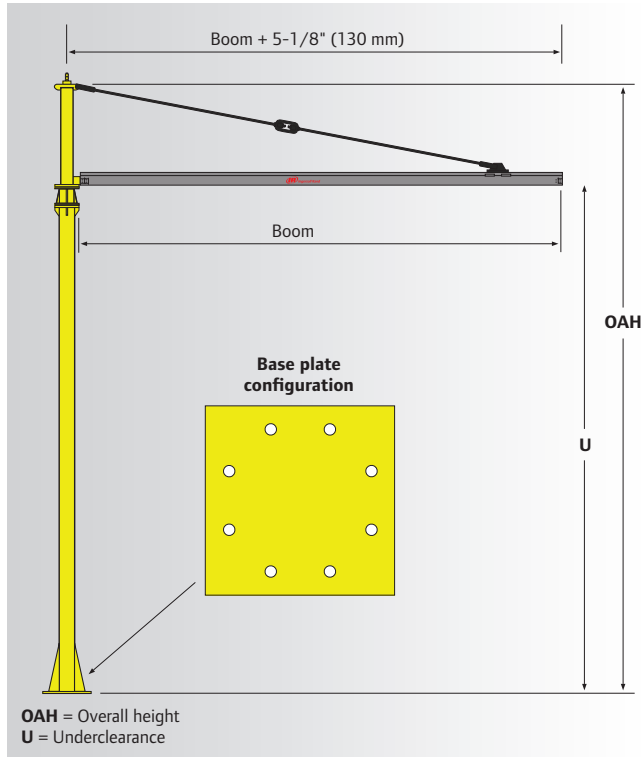

ZRS2 boom type 360° rotation

8082JS2F04144	4' (1.22)	820 (371.9)	43.18" (1097)	419 (190.5)
8055JS2F06144	6' (1.83)	550 (249.5)	43.18" (1097)	435 (197.7)
8041JS2F08144	8' (2.44)	410 (186)	43.18" (1097)	451 (205)
8033JS2F10144	10' (3.05)	330 (149.7)	43.18" (1097)	467 (212.3)
8027JS2F12144	12' (3.66)	270 (122.5)	43.18" (1097)	483 (219.5)
8023JS2F14144	14' (4.27)	230 (104.3)	43.18" (1097)	499 (226.8)
8020JS2F16144	16' (4.88)	200 (90.7)	43.18" (1097)	515 (234.1)
8018JS2F18144	18' (5.49)	180 (81.6)	43.18" (1097)	531 (241.4)
8016JS2F20144	20' (6.1)	160 (72.6)	43.18" (1097)	547 (248.6)

ZRA1 boom type 360° rotation

8082JA1F04144	4' (1.22)	820 (371.9)	42.09" (1069)	415 (188.6)
8055JA1F06144	6' (1.83)	550 (249.5)	42.09" (1069)	423 (192.3)
8041JA1F08144	8' (2.44)	410 (186)	42.09" (1069)	431 (195.9)
8033JA1F10144	10' (3.05)	330 (149.7)	42.09" (1069)	439 (199.5)
8027JA1F12144	12' (3.66)	270 (122.5)	42.09" (1069)	447 (203.2)
8023JA1F14144	14' (4.27)	230 (104.3)	42.09" (1069)	455 (206.8)
8020JA1F16144	16' (4.88)	200 (90.7)	42.09" (1069)	463 (210.5)
8018JA1F18144	18' (5.49)	180 (81.6)	42.09" (1069)	471 (214.1)
8016JA1F20144	20' (6.1)	160 (72.6)	42.09" (1069)	479 (217.7)

ZRA2 boom type 360° rotation

8082JA2F04144	4' (1.22)	820 (371.9)	43.25" (1099)	419 (190.5)
8055JA2F06144	6' (1.83)	550 (249.5)	43.25" (1099)	435 (197.7)
8041JA2F08144	8' (2.44)	410 (186)	43.25" (1099)	451 (205)
8033JA2F10144	10' (3.05)	330 (149.7)	43.25" (1099)	467 (212.3)
8027JA2F12144	12' (3.66)	270 (122.5)	43.25" (1099)	483 (219.5)
8023JA2F14144	14' (4.27)	230 (104.3)	43.25" (1099)	499 (226.8)
8020JA2F16144	16' (4.88)	200 (90.7)	43.25" (1099)	515 (234.1)
8018JA2F18144	18' (5.49)	180 (81.6)	43.25" (1099)	531 (241.4)
8016JA2F20144	20' (6.1)	160 (72.6)	43.25" (1099)	547 (248.6)

For applications not covered on this sheet or pallet-based applications, consult the factory.

Dimensional notes:

ZRA1, ZRA2 and ZRS2 (medium)

- U^o Standard columns 6" x 6" x 1/4" designed for 168 in (14 ft/4.27m) underclearance or less.
- P Base plate 3/4" x 18" x 18", 8-holes 7/8" diameter on a 16" (406.4 mm) bolt circle. 3/4" stud anchors or bolts are to be supplied by the customer.

Zimmerman Series Jib Cranes

700J (220 degree):

ZRA1 boom type 220° rotation (light)

Part No.	Boom ft (m)	Capacity lb (kg)	OAH = U + in (mm)	Weight lb (kg)
7090JA1F04144	4' (1.22)	900 (408.2)	38" (965)	375 (170.5)
7061JA1F06144	6' (1.83)	610 (276.7)	38" (965)	383 (174.1)
7046JA1F08144	8' (2.44)	460 (208.7)	38" (965)	391 (177.7)
7037JA1F10144	10' (3.05)	370 (167.8)	38" (965)	399 (181.4)
7030JA1F12144	12' (3.66)	300 (136.1)	38" (965)	407 (185)
7026JA1F14144	14' (4.27)	260 (117.9)	38" (965)	414 (188.2)
7023JA1F16144	16' (4.88)	230 (104.3)	38" (965)	423 (192.3)
7020JA1F18144	18' (5.49)	200 (90.7)	38" (965)	431 (195.9)
7016JA1F20144	20' (6.1)	160 (72.6)	38" (965)	439 (199.5)

ZRA2 boom type 220° rotation (medium)

Part No.	Boom ft (m)	Capacity lb (kg)	OAH = U + in (mm)	Weight lb (kg)
7200JA2F04144	4' (1.22)	2,000 (907.2)	39" (991)	660 (300)
7140JA2F06144	6' (1.83)	1,400 (635)	39" (991)	675 (306.8)
7105JA2F08144	8' (2.44)	1,050 (476.3)	39" (991)	690 (313.6)
7080JA2F10144	10' (3.05)	800 (362.9)	39" (991)	705 (320.5)
7070JA2F12144	12' (3.66)	700 (317.5)	39" (991)	720 (327.3)
7060JA2F14144	14' (4.27)	600 (272.2)	39" (991)	735 (334.1)
7050JA2F16144	16' (4.88)	500 (226.8)	39" (991)	782 (355.5)
7045JA2F18144	18' (5.49)	450 (204.1)	39" (991)	797 (362.3)
7040JA2F20144	20' (6.1)	400 (181.4)	39" (991)	812 (369.1)

ZRA2 boom type 220° rotation (heavy)

Part No.	Boom ft (m)	Capacity lb (kg)	OAH = U + in (mm)	Weight lb (kg)
7200JA2F06144	6' (1.83)	2,000 (907.2)	39" (991)	925 (420.5)
7200JA2F08144	8' (2.44)	2,000 (907.2)	39" (991)	940 (427.3)
7160JA2F10144	10' (3.05)	1,600 (725.7)	39" (991)	955 (434.1)
7135JA2F12144	12' (3.66)	1,350 (612.3)	39" (991)	970 (441)
7115JA2F14144	14' (4.27)	1,150 (521.6)	39" (991)	985 (447.7)
7100JA2F16144	16' (4.88)	1,000 (453.6)	51" (1,295)	1,000 (454.5)
7080JA2F18144	18' (5.49)	800 (362.9)	51" (1,295)	1,065 (484.1)
7065JA2F20144	20' (6.1)	650 (294.8)	51" (1,295)	1,080 (491)

ZRS2 boom type 220° rotation (medium)

Part No.	Boom ft (m)	Capacity lb (kg)	OAH = U + in (mm)	Weight lb (kg)
7200JS2F04144	4' (1.22)	2,000 (907.2)	39" (991)	660 (300)
7140JS2F06144	6' (1.83)	1,400 (635)	39" (991)	675 (306.8)
7105JS2F08144	8' (2.44)	1,050 (476.3)	39" (991)	690 (313.6)
7085JS2F10144	10' (3.05)	850 (385.6)	39" (991)	705 (320.5)
7070JS2F12144	12' (3.66)	700 (317.5)	39" (991)	720 (327.3)
7060JS2F14144	14' (4.27)	600 (272.2)	39" (991)	735 (334.1)
7053JS2F16144	16' (4.88)	530 (240.4)	39" (991)	782 (355.5)
7048JS2F18144	18' (5.49)	480 (217.7)	39" (991)	797 (362.3)
7042JS2F20144	20' (6.1)	420 (190.5)	39" (991)	812 (369.1)

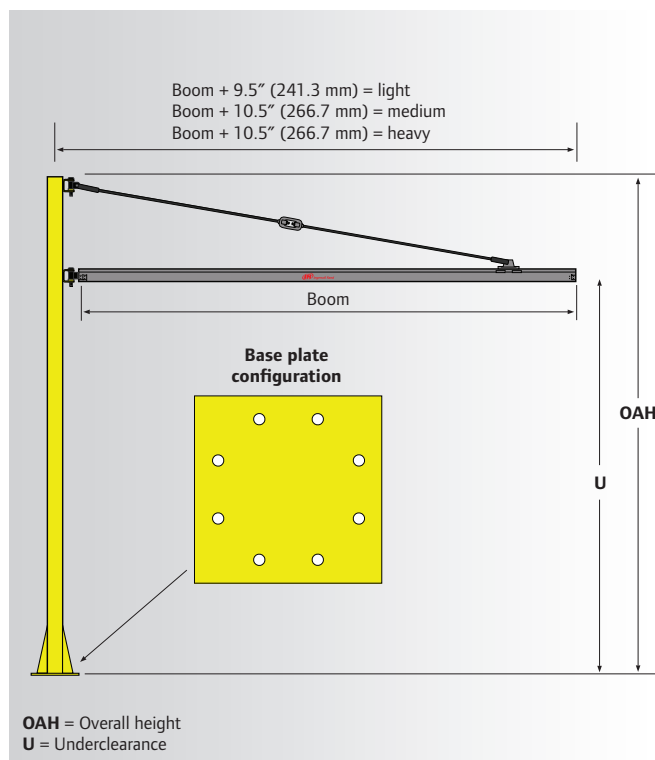

ZRS3 boom type 220° rotation (heavy)

Part No.	Boom ft (m)	Capacity lb (kg)	OAH = U + in (mm)	Weight lb (kg)
7200JA2F06144	6' (1.83)	2,000 (907.2)	39" (991)	925 (420.5)
7200JA2F08144	8' (2.44)	2,000 (907.2)	39" (991)	940 (427.3)
7160JA2F10144	10' (3.05)	1,600 (725.7)	39" (991)	955 (434.1)
7135JA2F12144	12' (3.66)	1,350 (612.3)	39" (991)	970 (441)
7115JA2F14144	14' (4.27)	1,150 (521.6)	39" (991)	985 (447.7)
7100JA2F16144	16' (4.88)	1,000 (453.6)	51" (1,295)	1,000 (454.5)
7080JA2F18144	18' (5.49)	800 (362.9)	51" (1,295)	1,065 (484.1)
7065JA2F20144	20' (6.1)	650 (294.8)	51" (1,295)	1,080 (491)

For applications not covered on this sheet or pallet-based applications, consult the factory.

Dimensional notes:

ZRA1 (light)

- U" Standard columns 6" x 6" x 1/4" designed for 168 in (14 ft/4.27 m) underclearance or less.
- P Base plate 3/4" x 18" x 18", 8-holes 7/8" diameter on a 16" (406.4 mm) bolt circle.

3/4" stud anchors or bolts are to be supplied by the customer.

ZRA2 (medium)

- U" Standard columns 8" x 8" x 1/4" designed for 168 in (14 ft/4.27 m) underclearance or less.
- P Base plate 3/4" x 24" x 24", 8-holes 7/8" diameter on a 20" (508 mm) bolt circle.

3/4" stud anchors or bolts are to be supplied by the customer.

ZRA2 (heavy)

- U" Standard columns 8" x 8" x 1/2" designed for 168 in (14 ft/4.27 m) underclearance or less.
- P Base plate 3/4" x 24" x 24", 8-holes 7/8" diameter on a 20" (508 mm) bolt circle.

3/4" stud anchors or bolts are to be supplied by the customer.

ZRS2 (medium)

- U" Standard columns 8" x 8" x 1/4" designed for 168 in (14 ft/4.27 m) underclearance or less.
- P Base plate 3/4" x 24" x 24", 8-holes 7/8" diameter on a 20" (508 mm) bolt circle.

3/4" stud anchors or bolts are to be supplied by the customer.

ZRS3 (heavy)

- U" Standard columns 8" x 8" x 1/2" designed for 168 in (14 ft/4.27 m) underclearance or less.
- P Base plate 3/4" x 24" x 24", 8-holes 7/8" diameter on a 20" (508 mm) bolt circle.

3/4" stud anchors or bolts are to be supplied by the customer.

Zimmerman Series Jib Cranes

700JW (wall mount):

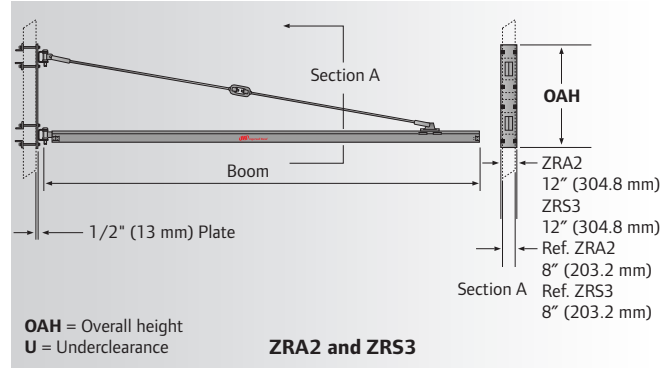
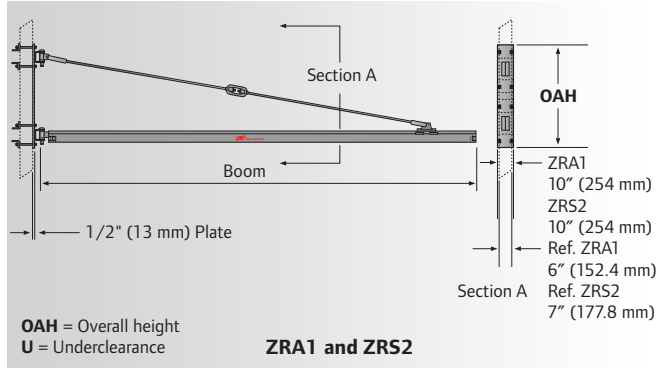

ZRA1 boom type wall mount (light)

Part No.	Boom ft (m)	Capacity lb (kg)	OAH in (mm)	Weight lb (kg)
7100JA1W04	4' (1.22)	1,000 (453.6)	44" (1118)	120 (54.5)
7100JA1W06	6' (1.83)	1,000 (453.6)	44" (1118)	131 (59.5)
7100JA1W08	8' (2.44)	1,000 (453.6)	44" (1118)	142 (64.5)
7080JA1W10	10' (3.05)	800 (362.9)	44" (1118)	153 (69.5)
7050JA1W12	12' (3.66)	500 (226.8)	44" (1118)	164 (74.5)
7036JA1W14	14' (4.27)	360 (163.3)	44" (1118)	175 (79.5)
7026JA1W16	16' (4.88)	260 (117.9)	44" (1118)	186 (84.5)
7020JA1W18	18' (5.49)	200 (90.7)	44" (1118)	197 (89.5)
7016JA1W20	20' (6.1)	160 (72.6)	44" (1118)	208 (94.5)

ZRA2 boom type wall mount (heavy)

Part No.	Boom ft (m)	Capacity lb (kg)	OAH in (mm)	Weight lb (kg)
7200JA2W04	4' (1.22)	2,000 (907.2)	44" (1118)	145 (65.9)
7200JA2W06	6' (1.83)	2,000 (907.2)	44" (1118)	154 (70)
7200JA2W08	8' (2.44)	2,000 (907.2)	44" (1118)	181 (82.3)
7190JA2W10	10' (3.05)	1,900 (861.8)	44" (1118)	199 (90.5)
7160JA2W12	12' (3.66)	1,600 (725.7)	44" (1118)	217 (98.6)
7135JA2W14	14' (4.27)	1,350 (612.3)	44" (1118)	235 (106.8)
7100JA2W16	16' (4.88)	1,000 (453.6)	56" (1423)	266 (120.9)
7080JA2W18	18' (5.49)	800 (362.9)	56" (1423)	310 (140.9)
7060JA2W20	20' (6.1)	600 (272.2)	56" (1423)	354 (160.9)

ZRS2 boom type wall mount (medium)

Part No.	Boom ft (m)	Capacity lb (kg)	OAH in (mm)	Weight lb (kg)
7200JS2W04	4' (1.22)	2,000 (907.2)	44" (1118)	145 (65.9)
7200JS2W06	6' (1.83)	2,000 (907.2)	44" (1118)	163 (74.1)
7200JS2W08	8' (2.44)	2,000 (907.2)	44" (1118)	181 (82.3)
7190JS2W10	10' (3.05)	1,900 (861.8)	44" (1118)	199 (90.5)
7160JS2W12	12' (3.66)	1,600 (725.7)	44" (1118)	217 (98.6)
7100JS2W14	14' (4.27)	1,000 (453.6)	44" (1118)	235 (106.8)
7080JS2W16	16' (4.88)	800 (362.9)	56" (1423)	266 (120.9)
7060JS2W18	18' (5.49)	600 (272.2)	56" (1423)	310 (140.9)
7045JS2W20	20' (6.1)	450 (204.1)	56" (1423)	354 (160.9)

ZRS3 boom type wall mount (heavy)

Part No.	Boom ft (m)	Capacity lb (kg)	OAH in (mm)	Weight lb (kg)
7200JS3W04	4' (1.22)	2,000 (907.2)	44" (1118)	146 (66.4)
7200JS3W06	6' (1.83)	2,000 (907.2)	44" (1118)	166 (75.5)
7200JS3W08	8' (2.44)	2,000 (907.2)	44" (1118)	186 (84.5)
7190JS3W10	10' (3.05)	1,900 (861.8)	44" (1118)	206 (93.6)
7160JS3W12	12' (3.66)	1,600 (725.7)	44" (1118)	226 (102.7)
7135JS3W14	14' (4.27)	1,350 (612.3)	44" (1118)	246 (111.8)
7100JS3W16	16' (4.88)	1,000 (453.6)	56" (1423)	278 (126.4)
7080JS3W18	18' (5.49)	800 (362.9)	56" (1423)	322 (146.6)
7060JS3W20	20' (6.1)	600 (272.2)	56" (1423)	366 (166.4)

Zimmerman Series Jib Cranes

900J low profile (360 degree):

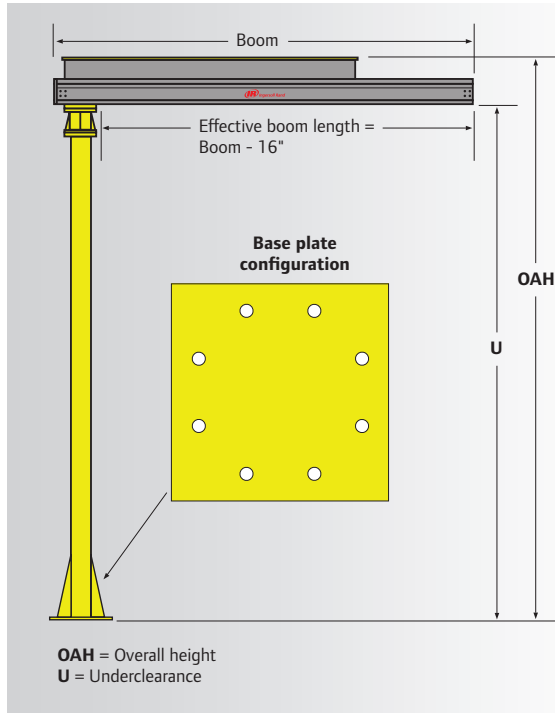

ZRA2 boom type 360° rotation (heavy)

Part No.	Boom ft (m)	Capacity lb (kg)	OAH = U + in (mm)	Weight lb (kg)
9082JA2TF04144	4' (1.22)	820 (371.9)	13.03" (340)	410 (186)
9055JA2TF06144	6' (1.83)	550 (249.5)	13.03" (340)	440 (199.6)
9041JA2TF08144	8' (2.44)	410 (186)	13.03" (340)	470 (213.2)
9033JA2TF10144	10' (3.05)	330 (149.7)	13.03" (340)	500 (226.8)
9027JA2TF12144	12' (3.66)	270 (122.5)	13.03" (340)	530 (240.4)
9023JA2TF14144	14' (4.27)	230 (104.3)	13.03" (340)	560 (254)
9020JA2TF16144	16' (4.88)	200 (90.7)	13.03" (340)	590 (267.6)
9018JA2TF18144	18' (5.49)	180 (81.6)	13.03" (340)	620 (281.2)
9016JA2TF20144	20' (6.1)	160 (72.6)	13.03" (340)	650 (294.8)

Note:
Effective boom length = Boom length - 16"

Dimensional notes:
Column: 6" x 6" x 1/4" designed for 168 in (14 ft/4.27 m) underclearance or less

Base plate:
3/4" x 18" x 18", 8 holes 7/8" diameter on a 16" (406.4 mm) bolt circle
3/4" stud anchors or bolts are to be supplied by the customer.

Example: 7105JS2F08144

Jib Crane model driver

Style 7	Capacity 105 lb kg	Jib J	Rail Type S2	Mount Type F	Boom Length 08 ft m	Underclearance 144 in mm
700J (220°) = 7 800J (360°) = 8 900J (360°) = 9	105 = 1050 476	J = Jib	A1 = ZRA1 A2 = ZRA2 S2 = ZRS2 S3 = ZRS3 A2T = ZRA2T	F = Floor W = Wall	04 = 4 1.22 06 = 6 1.83 08 = 8 2.44 10 = 10 3.05 12 = 12 3.66 14 = 14 4.27 16 = 16 4.88 18 = 18 5.49 20 = 20 6.10	144 = 144 3657.6 Note: Standard underclearance available up to 168 in.

Zimmerman Series Jib Cranes

Accessories:

Air supply kits

Size	Part No.
3/8"	90027
1/2"	90028

Note:
Includes filter regulator assembly with brackets, tagline assembly, and coiled hose.

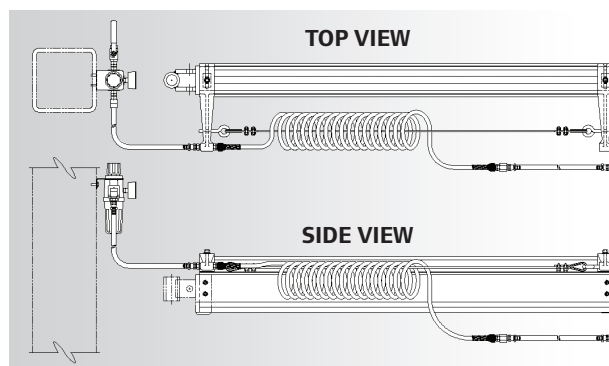

Electrification kits

Boom	Part No.
Up to 12'	ZHS90090-1
Greater than 12'	ZHS90090-2

Note:
Includes 2 suspension brackets, 1 anchor bracket, variable length tag line wire with clamps and eyebolt assembly, and cable trolleys.

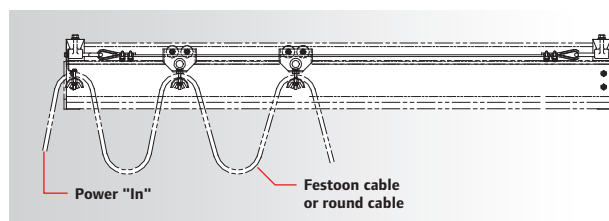

Hoist trolleys

Boom	Capacity lb (kg)	Part No.
ZRA1	500 (225)	ZHS30313
ZRA1	1,000 (450)	30303
ZRA2	1,000 (450)	ZHS30314
ZRA2	2,000 (900)	30906
ZRS2/3	1,000 (450)	ZHS30315
ZRS2/3	2,000 (900)	30830

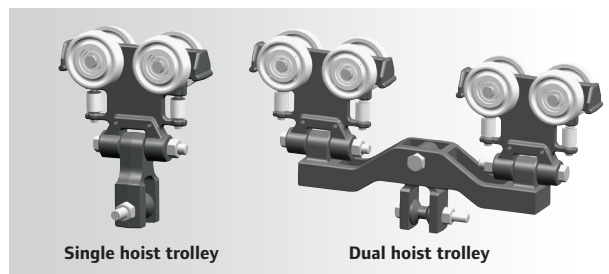

Adjustable boom rotation stops

Jib Series	Part No.
700J Series - 220° Rotation	ZHS42982
800J and 900J Series - 360° Rotation	42203000

Also available upon request:

- ▶ Portable pallet base — Provides jib mobility using a fork truck compatible base
- ▶ Custom designs for special applications

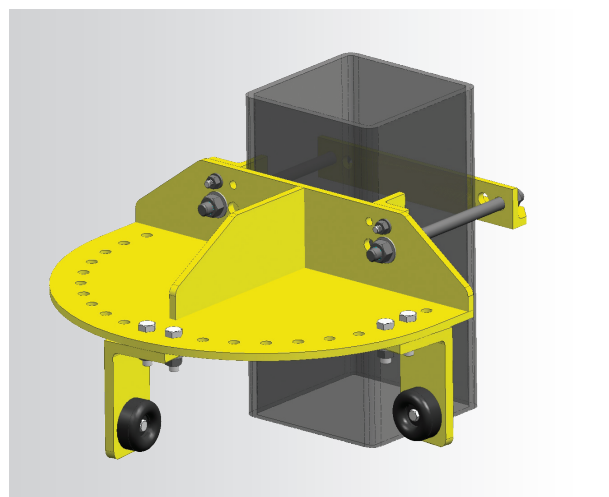

Balancers

The strength behind Ingersoll Rand ergonomic handling



Ingersoll Rand offers:

- ▶ Pneumatic balancers
- ▶ IntelLIFT® intelligent assist devices
- ▶ Mechanical spring balancers

Zimmerman Series Pneumatic Balancers

The Ingersoll Rand Pneumatic Balancer **ADVANTAGE**

- ▶ **Precise, strain-free positioning** — Float leaves both hands free to raise, lower, or shift the load with virtually no resistance; no more “hoist control” hit-and-miss spotting
- ▶ **Simple adjustment** — Clear access to air-flow calibration controls allows quick, easy adjustment of the float
- ▶ **Rugged reliability** — For continuous duty with minimal maintenance

PLUS:

- ▶ **Low air consumption** — Approximately 1/8 cfm required per cycle (one fiftieth of that of an air hoist) means very low energy costs
- ▶ **Clean, oil-free operation** — Pre-lubricated design eliminates air line lubrication and oil mist exhaust; ideal for food processing and clean manufacturing environments

Safety is standard

- ▶ Built-in overload protection — The lifted load can never exceed the unit’s maximum rated capacity
- ▶ Minimal cable recoil due to loss of load — If the load is accidentally lost, a centrifugal brake (Z brake) automatically stops rapid upward cable travel

Versatile configuration

- ▶ Wide range of capacities up to 2,000 lbs (907 kg)
- ▶ Added protection — The optional Z Stop offers protection against the drifting of loads in the event the main air supply is lost
- ▶ Cable travel — 40 to 120 inches (1016 to 3048 mm) depending on the model
- ▶ Controls — ZA (pendant) controls let you handle varying loads; a BA (single) balance control is ideal for a constant load, and an EA for 2 loads
- ▶ Mounting — Suspension kits for Ingersoll Rand and other enclosed track manufacturers as well as I-beam, patented track, and hook mount
- ▶ CE certification — Meets the requirements for the European community



Z Stop: The optional Z Stop is a patented device that will eliminate the down-drift of suspended loads or tools during shut down or at night when the air supply is shut off. The Z Stop will stop drift within 6 inches (152.4 mm) and put the Balance Air into a mechanically locked position preventing damage to tools or objects below the suspended load. Available for use on all 10 inch (254 mm) diameter units.



Z Brake Safety Retraction System (Patent No. 5,522,581):

Standard on all units, prevents violent retraction in the event of a sudden release or loss of load. The brake will also eliminate excessive upward acceleration of a no load hook when the “up” button is pressed in fully.

Suspension lugs: Fits all Ingersoll Rand suspensions and most trolleys from other manufacturers.

Rugged steel housing: All steel housing for added durability

Injection-molded reel: Engineered plastic for excellent durability and wear resistance.

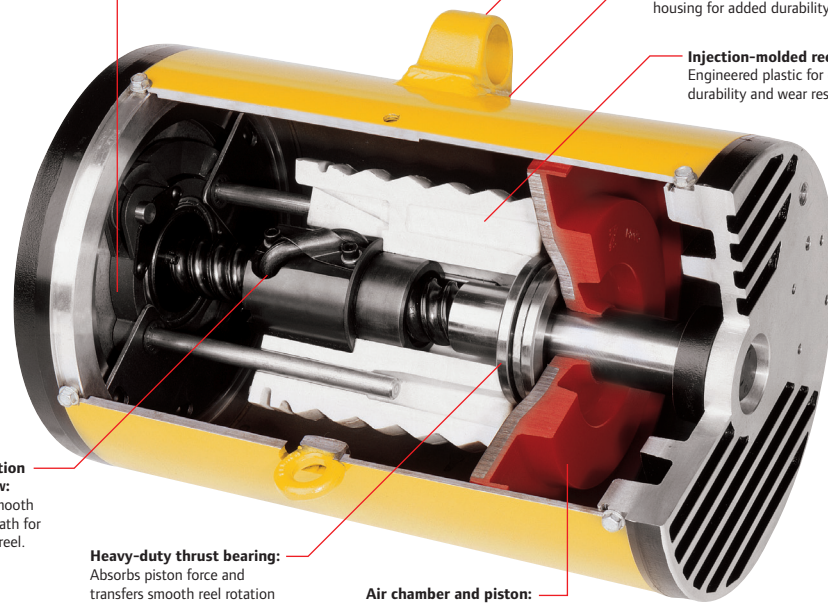

Anti-friction ball screw: Creates smooth rotation path for the cable reel.

Heavy-duty thrust bearing: Absorbs piston force and transfers smooth reel rotation over the ball screw.

Low-friction cable guide (not shown): Ensures smooth cable feed on and off the reel.

Air chamber and piston: Forms the heart of the unit. Air entering the chamber pushes the piston to rotate the spool, wind the cable, and lift the load. Exhausting air lowers the load. Regulating this flow balances the load, creating a zero gravity float.

Zimmerman Series Pneumatic Balancers

50 to 2,000 lb (22 to 909 kg) capacity

Control options:

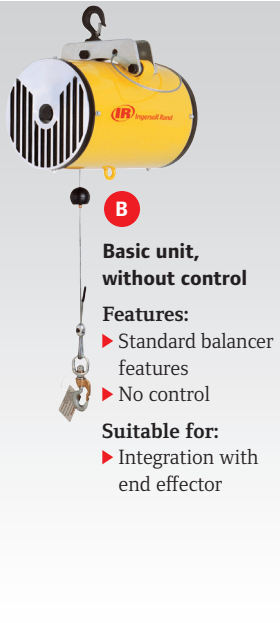

B

Basic unit, without control

Features:

- ▶ Standard balancer features
- ▶ No control

Suitable for:

- ▶ Integration with end effector



ZA

Balancer with pendant control

Features:

- ▶ Ergonomic up / down pendant control
- ▶ High speed precise positioning
- ▶ 12 ft (3.7 m) standard hose length

Suitable for:

- ▶ Pick and place
- ▶ Precision assembly

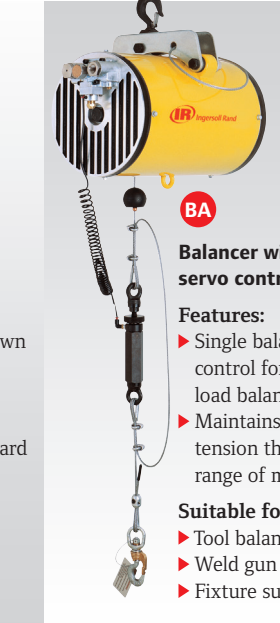

BA

Balancer with servo control

Features:

- ▶ Single balance control for single load balancing
- ▶ Maintains constant tension through full range of motion

Suitable for:

- ▶ Tool balancing
- ▶ Weld gun suspension
- ▶ Fixture suspension



EA

Balancer with high load, low load, no load control

Features:

- ▶ Load balancing for 3 loads (high, low, no load)
- ▶ Pendant with rotary thumb switch to select load
- ▶ 12 ft (3.7 m) standard hose length

Suitable for:

- ▶ Multiple load balancing
- ▶ End effector balancing (loaded/unloaded)

B	ZA	BA	EA	Capacity lb (kg)	Travel in (mm)	Net Weight lb (kg)
SINGLE WIRE ROPE						
BW015080 ¹	ZAW015080 ¹	BAW015080 ¹	EAW015080 ¹	150 (68)	80" (2032)	50 (23)
BW020120	ZAW020120	BAW020120	EAW020120	200 (90)	120" (3048)	62 (28)
BW020120S ²	ZAW020120S ²	BAW020120S ²	EAW020120S ²	200 (90)	120" (3048)	62 (28)
BW032080S ²	ZAW032080S ²	BAW032080S ²	EAW032080S ²	325 (147)	80" (2032)	62 (28)
BW035080 ¹	ZAW035080 ¹	BAW035080 ¹	EAW035080 ¹	350 (158)	80" (2032)	62 (28)
BW050080	ZAW050080	BAW050080	EAW050080	500 (227)	80" (2032)	110 (50)
BW050080S ²	ZAW050080S ²	BAW050080S ²	EAW050080S ²	500 (227)	80" (2032)	110 (50)
REEVED WIRE ROPE						
BW040060	ZAW040060	BAW040060	EAW040060	400 (181)	60" (1524)	67 (30)
BW040060S ²	ZAW040060S ²	BAW040060S ²	EAW040060S ²	400 (181)	60" (1524)	67 (30)
BW065040S ²	ZAW065040S ²	BAW065040S ²	EAW065040S ²	650 (294)	40" (1016)	67 (30)
BW070040 ¹	ZAW070040 ¹	BAW070040 ¹	EAW070040 ¹	700 (317)	40" (1016)	67 (30)
BW100040	ZAW100040	BAW100040	EAW100040	1,000 (453)	40" (1016)	115 (52)
BW100040S ²	ZAW100040S ²	BAW100040S ²	EAW100040S ²	1,000 (453)	40" (1016)	115 (52)
TANDEM WIRE ROPE						
BW040120	ZAW040120	BAW040120	EAW040120	400 (181)	120" (3048)	124 (56)
BW040120S ²	ZAW040120S ²	BAW040120S ²	EAW040120S ²	400 (181)	120" (3048)	124 (56)
BW065080S ²	ZAW065080S ²	BAW065080S ²	EAW065080S ²	650 (294)	80" (2032)	124 (56)
BW070080 ¹	ZAW070080 ¹	BAW070080 ¹	EAW070080 ¹	700 (317)	80" (2032)	124 (56)
BW100080	ZAW100080	BAW100080	EAW100080	1,000 (453)	80" (2032)	220 (100)
BW100080S ²	ZAW100080S ²	BAW100080S ²	EAW100080S ²	1,000 (453)	80" (2032)	220 (100)
TANDEM REEVED WIRE ROPE						
BW080060	ZAW080060	BAW080060	EAW080060	800 (360)	60" (1524)	129 (59)
BW080060S ²	ZAW080060S ²	BAW080060S ²	EAW080060S ²	800 (360)	60" (1524)	129 (59)
BW130040S ²	ZAW130040S ²	BAW130040S ²	EAW130040S ²	1,300 (589)	40" (1016)	129 (59)
BW140040 ¹	ZAW140040 ¹	BAW140040 ¹	EAW140040 ¹	1,400 (620)	40" (1016)	129 (59)
BW200040	ZAW200040	BAW200040	EAW200040	2,000 (900)	40" (1016)	225 (102)
BW200040S ²	ZAW200040S ²	BAW200040S ²	EAW200040S ²	2,000 (900)	40" (1016)	225 (102)

Selection Tips:

- ▶ Actual operating capacity is determined by available plant air pressure. Operating capacity decreases 1% for every 1 psi below 100 psi inlet air pressure. For example: at 50 psi, a 350 lb capacity balancer has a 175 lb operating capacity (350 X 50%)
- ▶ For lifting applications, working load should not exceed 80% of operating capacity
- ▶ Working load includes part weight and handling device weight

¹ Not available with Z-Stop safety device.

² Model delivered with Z-Stop as standard.

Zimmerman Series Pneumatic Balancers

50 to 2,000 lb (22 to 909 kg) capacity

Suspension options:

Option Code	Description	6.5" Dia. 150 lb Unit	10" Dia. >150 lb Units	Competitor Product
00	No suspension	-	-	NA
S2	ZRS2 steel rail	16300	16400	NA
S3	ZRS3 steel rail	16300	16400	NA
HM	Hook mount	16360	16460*	NA
TR	T-Rail / I-Beam	16320	16420*	NA
AT	ZRAT aluminum rail	16355	16455*	NA
A1	ZRA1 aluminum rail	16305	16405*	NA
A2	ZRA2 aluminum rail	16310	16410	NA
E4	ETA-4 aluminum rail	16344	16444*	Unified
E8	ETA-8 aluminum rail	16345	16445	Unified
K1	KBK1 steel rail	16325	16425*	Demag
K2	KBK2 steel rail	16315	16415	Demag
G1	Gorbel 1000# alum. series track	16307	16407*	Gorbel
G2	Gorbel 1000# steel series track	16307	16407*	Gorbel
K3	4" Aluminum	16344	16444*	Knight
K4	8" Aluminum	16345	16445	Knight
K5	8" Aluminum anti-kickback	16345	16445	Knight
K6	4" Steel	16325	16425*	Knight
K7	6" Steel	16315	16415	Knight
K8	7" Steel	16315	16415	Knight

Note:

* NOT compatible with tandem balancers

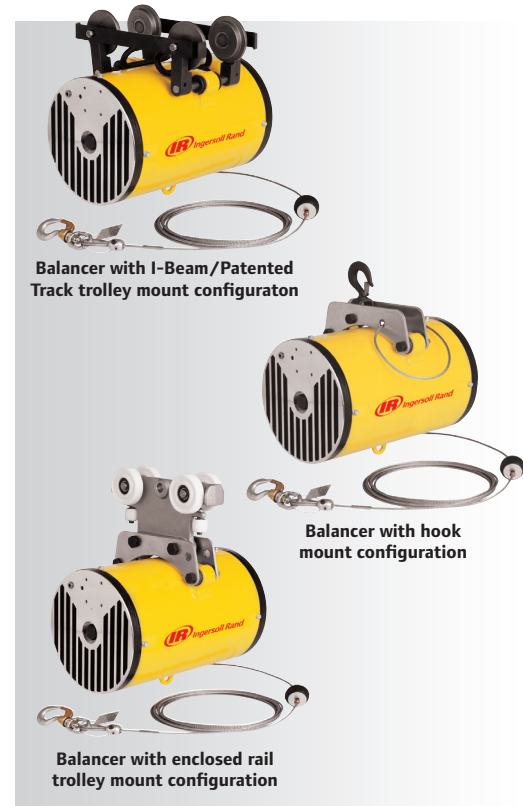

Example: BW020120SS2

Pneumatic Balancers model driver

Control B	Type W	Capacity 020	Travel 120	Z-Stop Option S	Suspension Option S2
B = Basic, no controls ZA = Pendant control BA = Servo control EA = High, low, no load control	W = Wire rope	020 = 200 lb (91 kg) For available capacities, refer to model number tables	120 = 120 inches (3048 mm) For available travel, refer to model number tables	S = Z-stop	S2 = ZRS2 steel rail For available suspension options, refer to suspension option table

Replacement part numbers

Z-Stop Option Code	Description	Part No.
S	Z-Stop, 200 lb capacity	13301
S	Z-Stop, 325 lb capacity	13311
S	Z-Stop, 500 lb capacity	13321
Control Options Code	Description	Part No.
B	Basic - no controls	N/A
ZA	Pendant control	15300-12
BA	Single balance control - 6.5" unit	15320
BA	Single balance control - 10" unit	15330
EA	High, low, no load control	15310-12

EZ Grip Ergonomic Control Handle

Quality handle manufactured by Ingersoll Rand, the world leader in ergonomically sound material handling equipment.



ZA Pendant Control (15300-12)

Zimmerman Series Pneumatic Balancers

Dimensions:

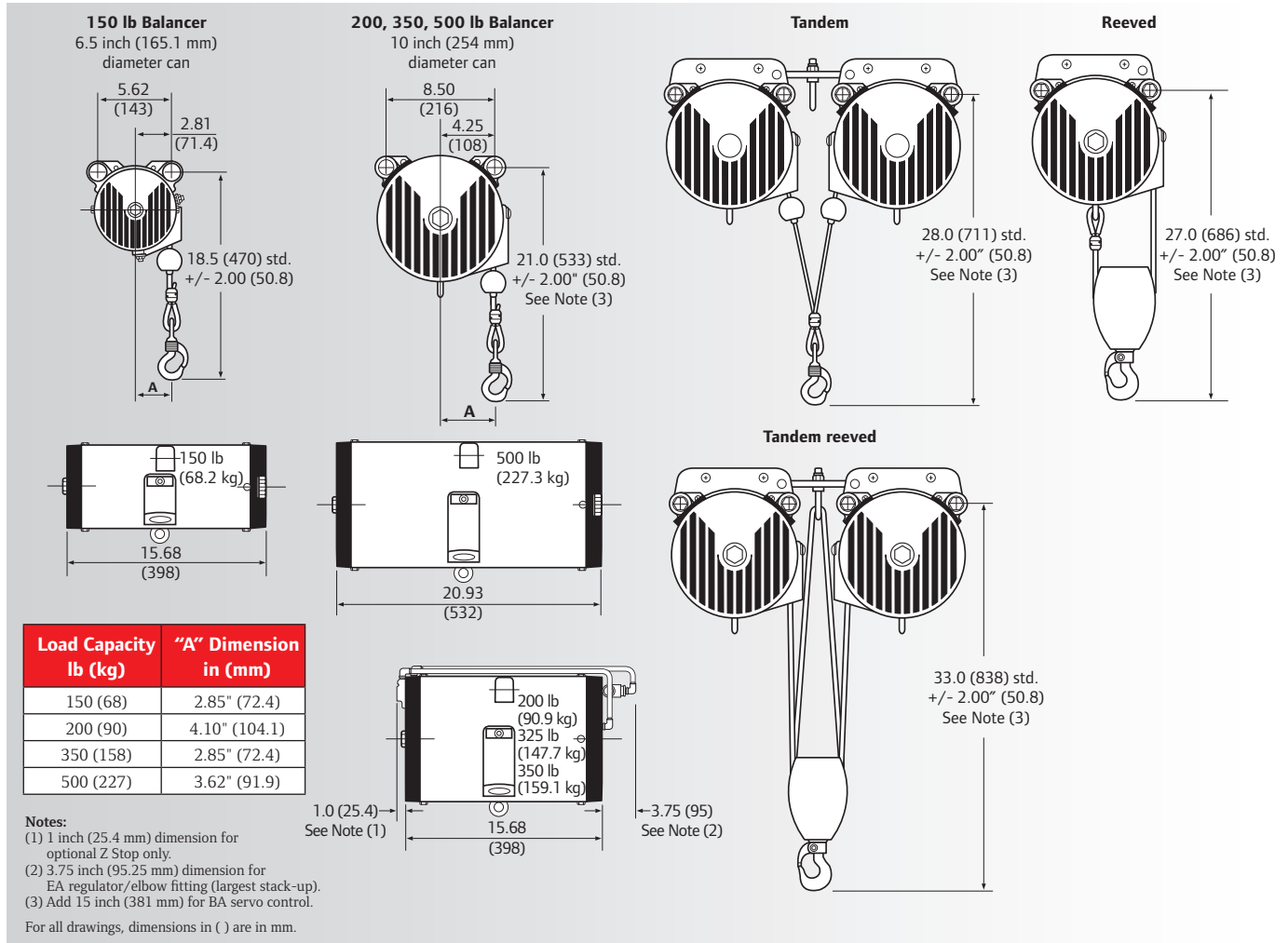

Also available:

BAW series tool balancer

This air unit offers an incredible 2 to 50 pound (0.9 to 22 kg) load capacity and our exclusive flotation feature.

Standard features:

- ▶ **Performance** — Float action provides ease of vertical travel, eliminating tension on load, making positioning capability far superior
- ▶ **Versatility** — No need to change model when making tool change; one model (BAW005060) covers entire 50 lb (22 kg) range
- ▶ **Headroom** — Requires only 20 inches (508 mm) from bottom of rail to bottom of hook
- ▶ **Adjustment** — Simple adjustment in seconds by means of external regulator
- ▶ **Sequencing** — Can be sequenced via air signal to perform timed or "stepped" operation
- ▶ **Maintenance** — Virtually maintenance-free. Normal maintenance can be done in place on the rail

BAW005060

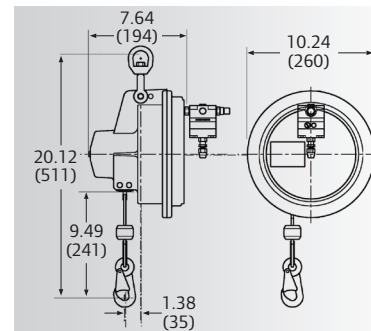

Part No.	Capacity lb (kg)	Travel in (mm)	Net Weight lb (kg)
SINGLE WIRE ROPE			
BAW005060	2 - 50 (0.9 - 22)	59" (1500)	19.8 (9)

Zimmerman IntelLIFT® Series Balancers

Intelligent Lifting Systems

What is IntelLIFT?

IntelLIFT is an intelligent assist device (IAD); it converts intuitive operator input into smooth, effortless up / down motion. The force-sensing control handle responds to operator input quickly and seamlessly for precise positioning of loads.

The Ingersoll Rand IntelLIFT Balancer **ADVANTAGE**

- ▶ **Self-balancing** — Intuitive speed control for different weights
- ▶ **Hands-on maneuvering** — IntelLIFT senses force input of the user and translates that to assisted lifting / lowering of the load without the need for up / down buttons
- ▶ **Float mode** — Throughout entire range of motion
- ▶ **Robust design** — Electric over air design allows continuous duty with minimal maintenance
- ▶ **Part present** — Eliminates potential to accidentally drop part
- ▶ **3-Speed select** — Enables speed selection to match application and operator comfort level

Same green features as the Pneumatic Balancer

- ▶ Low air consumption
- ▶ Clean, oil-free operation



Integrated IntelLIFT control module:

- ▶ Integral element of the balancer itself
- ▶ Simple programming of functions with a keypad and indicator lights
- ▶ Easy-to-read display window



Ergonomic control handle:



Zimmerman IntelLIFT® Series Balancers

Intelligent Lifting Systems

Control options:

 <p>IB</p> <p>IntelLIFT basic unit, without control</p> <p>Features:</p> <ul style="list-style-type: none"> ▶ No controls ▶ Standard IntelLIFT features <p>Suitable for:</p> <ul style="list-style-type: none"> ▶ Integration with end effector 	 <p>IA</p> <p>IntelLIFT with pendant control and pre-coil cable</p> <p>Features:</p> <ul style="list-style-type: none"> ▶ IntelLIFT ergonomic pendant control handle with up / down rocker switch ▶ Precise, high-speed positioning ▶ 12 ft (3.7 m) twin bonded pre-coil cable including pre-coil air hose for handling device integration <p>Suitable for:</p> <ul style="list-style-type: none"> ▶ Pick and place ▶ Precision assembly 	 <p>IC</p> <p>IntelLIFT with force-sensing control (without up / down buttons)</p> <p>Features:</p> <ul style="list-style-type: none"> ▶ IntelLIFT ergonomic force-sensing control handle ▶ Intuitive up / down control ▶ 12 ft (3.7 m) twin bonded pre-coil cable including pre-coil air hose for handling device integration <p>Suitable for:</p> <ul style="list-style-type: none"> ▶ High-cycle pick and place ▶ Precision assembly 	 <p>IS</p> <p>IntelLIFT with pendant control and straight cable</p> <p>Features:</p> <ul style="list-style-type: none"> ▶ IntelLIFT ergonomic pendant control handle with up / down rocker switch ▶ Precise, high-speed positioning ▶ 12 ft (3.7 m) straight electric cable <p>Suitable for:</p> <ul style="list-style-type: none"> ▶ Pick and place ▶ Precision assembly
---	--	--	---

IB	IA	IC	IS	Capacity lb (kg)	Travel in (mm)	Net Weight lb (kg)
SINGLE WIRE ROPE						
IBW015080*	IAW015080*	ICW015080*	ISW015080*	150 (68)	80" (2032)	60 (27)
IBW020120	IAW020120	ICW020120	ISW020120	200 (91)	114" (2896)	72 (33)
IBW033080	IAW033080	ICW033080	ISW033080	330 (150)	70" (1778)	72 (33)
IBW050080	IAW050080	ICW050080	ISW050080	500 (227)	74" (1880)	120 (54)
REEVED WIRE ROPE						
IBW040060	IAW040060	ICW040060	ISW040060	400 (182)	57" (1448)	65 (30)
IBW066040	IAW066040	ICW066040	ISW066040	660 (300)	35" (883)	77 (35)
IBW100040	IAW100040	ICW100040	ISW100040	1,000 (454)	37" (940)	125 (57)

*Not available with Z-Stop safety device

Selection Tips:

- ▶ Actual operating capacity is determined by available plant air pressure. Operating capacity decreases 1% for every 1 psi below 100 psi plant air pressure. For example: at 50 psi, a 200 lb capacity balancer has a 100 lb operating capacity (200 X 50%)
- ▶ For lifting applications, working load should not exceed 80% of operating capacity
- ▶ Working load includes part weight and handling device weight
- ▶ IC control option includes force sensing load cell which must be mounted to end effector for proper operation
- ▶ See following page for additional IntelLIFT options and complete model driver required to order product.

Zimmerman IntelLIFT® Series Balancers

Suspension options:

Option Code	Description	6.5" Dia. 150 lb Unit	10" Dia. >150 lb Units	Competitor Product
00	No suspension	-	-	NA
S2	ZRS2 steel rail	16300	16400	NA
S3	ZRS3 steel rail	16300	16400	NA
HM	Hook mount	16360	16460	NA
TR	T-Rail / I-Beam	16320	16420	NA
AT	ZRAT aluminum rail	16355	16455	NA
A1	ZRA1 aluminum rail	16305	16405	NA
A2	ZRA2 aluminum rail	16310	16410	NA
E4	ETA-4 aluminum rail	16344	16444	Unified
E8	ETA-8 aluminum rail	16345	16445	Unified
K1	KBK1 steel rail	16325	16425	Demag
K2	KBK2 steel rail	16315	16415	Demag
G1	Gorbel 1000# alum. series track	16307	16407	Gorbel
G2	Gorbel 1000# steel series track	16307	16407	Gorbel
K3	4" Aluminum	16344	16444	Knight
K4	8" Aluminum	16345	16445	Knight
K5	8" Aluminum anti-kickback	16345	16445	Knight
K6	4" Steel	16325	16425	Knight
K7	6" Steel	16315	16415	Knight
K8	7" Steel	16315	16415	Knight

Voltage option:

- ▶ 115V 50/60 Hz single phase
- ▶ 230V 50/60 Hz single phase

Power cord option:

- ▶ 6 ft (1.8 m) power cord



Example: IAW020120A21SP

IntelLIFT model driver

Control IA	Type W	Capacity 020 lb kg	Travel 120 in mm	Suspension A2	Voltage 1	Z-Stop S	Power Cord P
IB = IntelLIFT basic, no controls IA = IntelLIFT pendant control handle with 12' twin bond pre-coil cable IC = IntelLIFT force sensing control handle with 12' twin bond pre-coil cable IS = IntelLIFT pendant control handle with 12' straight electric cable	W = Wire rope	020 = 200 91 For available capacities, refer to model number tables	120 = 120" 3048 For available travel, refer to model number tables	A2 = ZRA2 aluminum rail For available suspension options, refer to suspension option table	1 = 115V 50/60 Hz 1 PH 2 = 230V 50/60 Hz 1 PH	S = Z-Stop	P = 6' Power cord 0 = None

Dimensions:

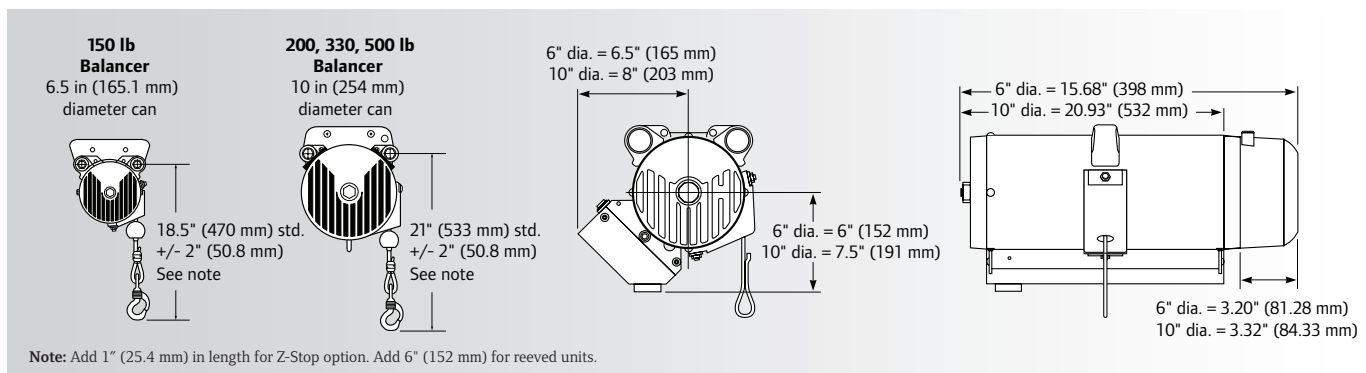

Zimmerman IntelLIFT® Series Balancers

Integrated solutions

A complete range of end effectors can be used with IntelLIFT controls for greater efficiency, from the simplest to the most complex device. The IntelLIFT unit incorporates a fully grounded, fault-protected electrical system, with fused circuits and memory that automatically reinstates function selections following a power interruption. In every respect, the Ingersoll Rand IntelLIFT air balancer is an essential solution for a more productive workplace; empowering individuals to work comfortably and effectively, significantly contributing to product and process quality.

The closed-loop feedback system delivers precise, responsive motion control suitable for a wide range of applications in:



Vehicle assembly

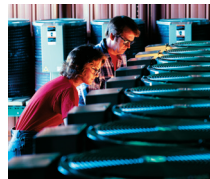

General industry

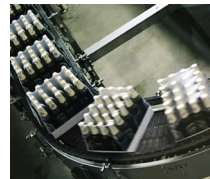

Beverage and warehouse



Biotechnology

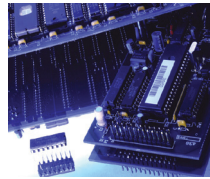

Electronics



Aerospace

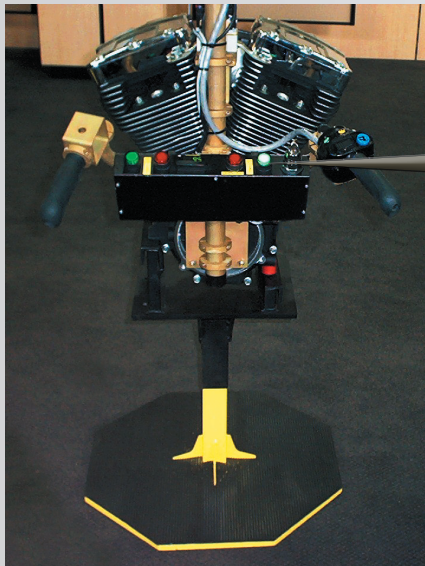

The engine-handling device shown uses the unique features of the IntelLIFT balancer. Features include: auto clamp, interlock, up control disable, weight sensing with automatic alarm, and keyed lockout.

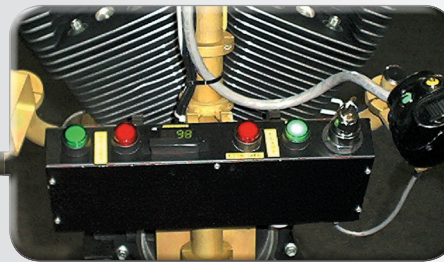

Error-proof assembly:

The device digitally displays the weight of the part picked up. Device will not allow the operator to move the part if not clamped properly. The key allows the operator the ability to lock the device. Allows 100 percent visual inspection of the assembly.

The warehouse-handling device shown is known for its versatility. The device mimics the human motion of picking up a part and placing it down. The same device can be used to pick up parts such as totes, trays, boxes, and milk crates. The self-balance feature allows the same device to pick up parts of different weights and sizes. Order P/N 16010209 in conjunction with IBW015080 IntelLIFT balancer.



Spring Balancers

The Ingersoll Rand Spring Balancer **ADVANTAGE**

- ▶ 50 models from which to choose
- ▶ Five different series to meet all balancing requirements
- ▶ Lifts ranging from 5 to 9 feet
- ▶ Covers weight-balancing needs from 1 to 363 pounds
- ▶ “Gravity-free” effect on intermediate, heavy, and super-duty models allows user to move tool with minimal effort
- ▶ Made of rugged die-cast aluminum
- ▶ Safety locking device on medium, heavy, and super-duty models prevents dropping of the tool should the spring fail
- ▶ Easy-to-use controls allow for accurate spring adjustment

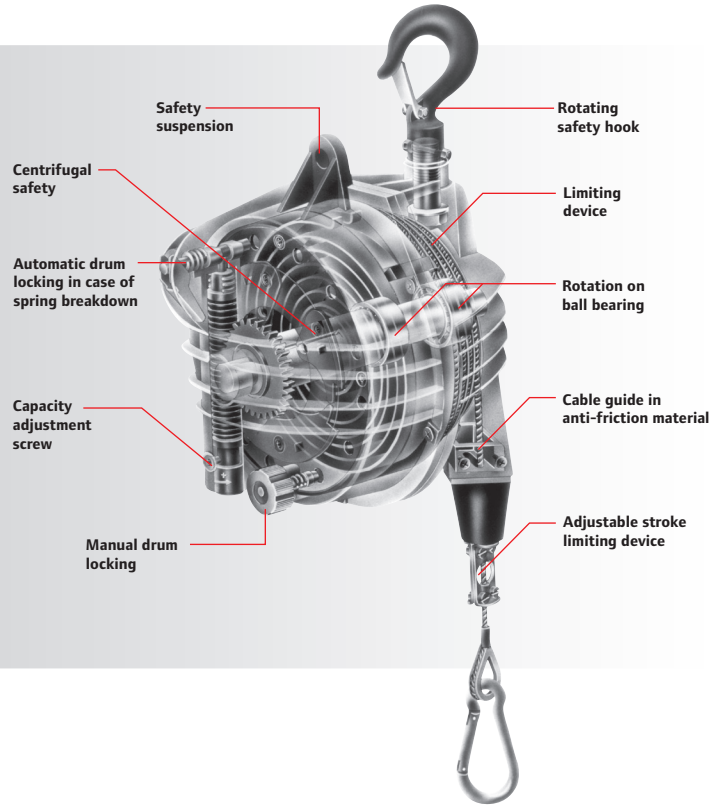

Medium-duty balancers

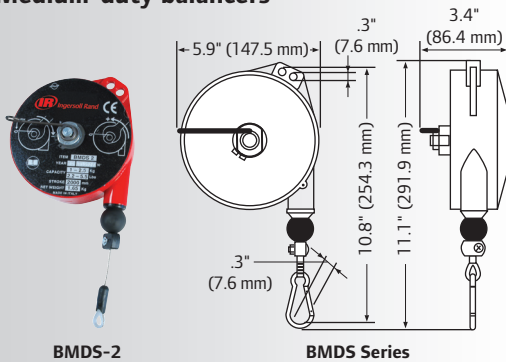

Medium-duty locking balancers

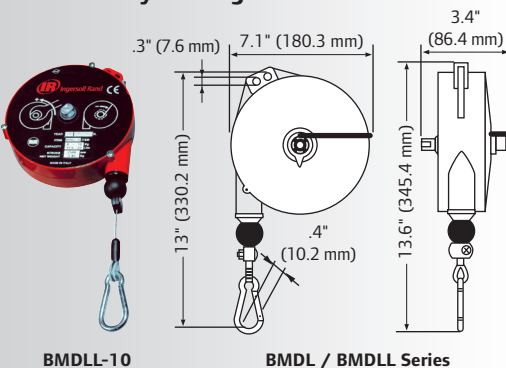

Part Number	Capacity lb (kg)	Weight of Balancer lb (kg)	Lift ft (mm)
MEDIUM-DUTY BALANCERS — 2.2 – 30 LB CAPACITY			
SHORT CABLE			
BMDS-2	2.2 – 5.5 (1 – 2.5)	4.4 (2)	6.5 (2000)
BMDS-4	4.4 – 8.8 (2 – 4)	4.4 (2)	6.5 (2000)
BMDS-6	8.8 – 13.2 (4 – 6)	5.1 (2.3)	6.5 (2000)
BMDS-8	13.2 – 17.6 (6 – 8)	5.5 (2.5)	6.5 (2000)
LONG CABLE			
BMDL-4	4.4 – 8.8 (2 – 4)	6.4 (2.9)	8.2 (2500)
BMDL-6	8.8 – 13.2 (4 – 6)	7.1 (3.2)	8.2 (2500)
BMDL-8	13.2 – 17.6 (6 – 8)	7.7 (3.5)	8.2 (2500)
BMDL-10	17.6 – 22 (8 – 10)	8.2 (3.7)	8.2 (2500)
BMDL-12	22 – 26.5 (10 – 12)	8.8 (4)	8.2 (2500)
BMDL-14	22 – 30 (10 – 14)	5.6 (2.5)	8.2 (2500)
BMDL-14-Y (Yellow)	22 – 30 (10 – 14)	5.6 (2.5)	8.2 (2500)
MEDIUM-DUTY LOCKING BALANCERS — 4.4 – 22 LB CAPACITY			
LONG CABLE			
BMDLL-4	4.4 – 8.8 (2 – 4)	6.6 (3)	8.2 (2500)
BMDLL-6	8.8 – 13.2 (4 – 6)	7.3 (3.3)	8.2 (2500)
BMDLL-8	13.2 – 17.6 (6 – 8)	7.9 (3.6)	8.2 (2500)
BMDLL-10	17.6 – 22 (8 – 10)	8.4 (3.8)	8.2 (2500)

- ▶ Safety device prevents dropping of load due to spring breakage (except BMDS-2)
- ▶ Anti-friction cable guide
- ▶ Adjustable stroke limiting device

Spring Balancers

Intermediate-duty balancers

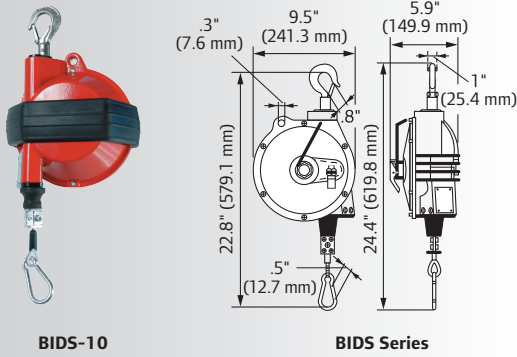

BIDS-10

BIDS Series

Part Number	Capacity lb (kg)	Weight of Balancer lb (kg)	Lift ft (mm)
INTERMEDIATE-DUTY BALANCERS — 8.8 – 55 LB CAPACITY			
BIDS-7	8.8 – 15.4 (4 – 7)	5 (2.26)	6.5 (2000)
BIDS-10	15.4 – 22 (7 – 10)	5.5 (2.49)	6.5 (2000)
BIDS-14	22 – 30.8 (10 – 14)	5.5 (2.49)	6.5 (2000)
BIDS-18	30.8 – 39.6 (14 – 18)	6.5 (2.95)	6.5 (2000)
BIDS-22	39.6 – 48.4 (18 – 22)	6.5 (2.95)	6.5 (2000)
BIDS-26	48.4 – 55 (22 – 25)	6.5 (2.95)	6.5 (2000)

- ▶ Safety device prevents load dropping due to spring breakage
- ▶ Anti-friction cable guide
- ▶ Adjustable stroke limiting device
- ▶ Upper rotary suspension
- ▶ Safety hook
- ▶ Auxiliary safety suspension

Heavy-duty balancers

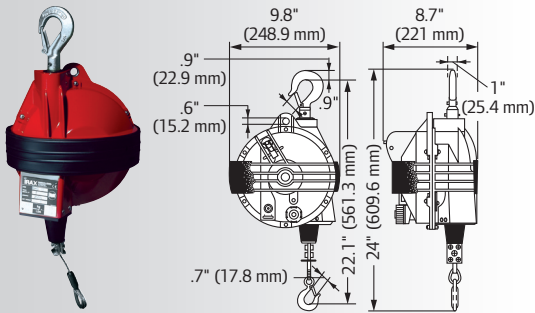

BHD-35

BHD Series

Part Number	Capacity lb (kg)	Weight of Balancer lb (kg)	Lift ft (mm)
HEAVY-DUTY BALANCERS — 22 – 143 LB CAPACITY			
BHD-15	22 – 33 (10 – 15)	22.7 (10.3)	6.5 (2000)
BHD-20	33 – 44 (15 – 20)	23.4 (10.6)	6.5 (2000)
BHD-25	44 – 55 (20 – 25)	24.7 (11.2)	6.5 (2000)
BHD-30	55 – 66 (25 – 30)	25.4 (11.5)	6.5 (2000)
BHD-35	66 – 77 (30 – 35)	26 (11.8)	6.5 (2000)
BHD-45	77 – 99 (35 – 45)	27.3 (12.4)	6.5 (2000)
BHD-55	99 – 121 (45 – 55)	27.6 (12.5)	6.5 (2000)
BHD-65	121 – 143 (55 – 65)	30 (13.6)	6.5 (2000)

- ▶ Safety device prevents load dropping due to spring breakage
- ▶ Upper suspension with rotary safety hook
- ▶ Precision guided cable winding prevents jamming
- ▶ Anti-friction cable guide
- ▶ Worm screw capacity adjustment
- ▶ Spring drum assembly
- ▶ Floor controlled locking device for instant manual clamping or release (BIL-7343)



Additional information

Additional information about Ingersoll Rand Spring Balancers can be found in our Balancers Brochure (IRPS-0407-007)

An online "Balancer Finder" tool to assist with balancer selection can be found at:
http://www.irtools.com/accessories/pgs/user_balancers.aspx

Spring Balancers

Super-duty balancers



BSD-20

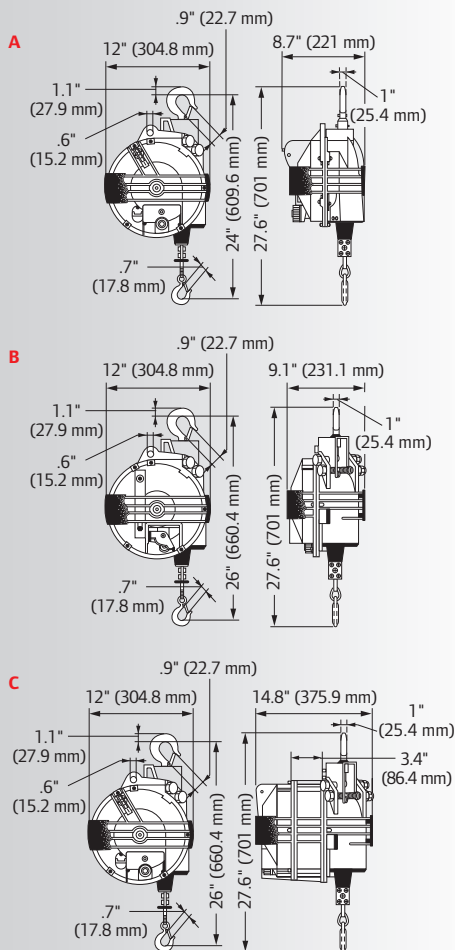

Compatible trolleys

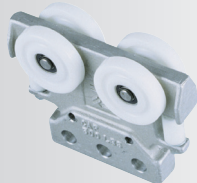

Part Number	Capacity lb (kg)	Weight of Balancer lb (kg)	Lift ft (mm)	Diagram
SUPER-DUTY BALANCERS — 33 – 363 LB CAPACITY				
BSD-20	33 – 44 (15 – 20)	41.9 (19)	8.2 (2500)	A
BSD-30	44 – 66 (20 – 30)	43.7 (19.8)	8.2 (2500)	A
BSD-40	66 – 88 (30 – 40)	45.9 (20.8)	8.2 (2500)	A
BSD-50	88 – 110 (40 – 50)	52.7 (23.9)	8.2 (2500)	A
BSD-60	110 – 132 (50 – 60)	56 (25.4)	8.2 (2500)	A
BSD-70	132 – 154 (60 – 70)	59.1 (26.8)	8.2 (2500)	B
BSD-80	154 – 176 (70 – 80)	61.3 (27.8)	8.2 (2500)	B
BSD-90	176 – 198 (80 – 90)	63.5 (28.8)	8.2 (2500)	B
BSD-100	198 – 220 (90 – 100)	78.5 (35.6)	8.2 (2500)	C
BSD-120	220 – 265 (100 – 120)	85.3 (338.7)	8.2 (2500)	C
BSD-140	265 – 309 (120 – 140)	92.2 (41.8)	8.2 (2500)	C
BSD-150	287 – 330 (130 – 150)	98.1 (44.5)	8.2 (2500)	C
BSD-165	330 – 363 (150 – 165)	106.3 (48.2)	8.2 (2500)	C
MEDIUM-DUTY LOCKING BALANCERS — 33 – 330 LB CAPACITY LONG CABLE				
BSDL-20	33 – 44 (15 – 20)	42.1 (19.1)	9.85 (3000)	A
BSDL-25	44 – 55 (20 – 25)	43.9 (19.9)	9.85 (3000)	A
BSDL-35	55 – 77 (25 – 35)	46.1 (20.9)	9.85 (3000)	A
BSDL-45	77 – 99 (35 – 45)	52.5 (23.8)	9.85 (3000)	B
BSDL-50	88 – 110 (40 – 50)	52.7 (23.9)	9.85 (3000)	B
BSDL-60	110 – 132 (50 – 60)	55.8 (25.3)	9.85 (3000)	B
BSDL-70	132 – 154 (60 – 70)	58.9 (26.7)	9.85 (3000)	B
BSDL-80	154 – 176 (70 – 80)	61.7 (28)	9.85 (3000)	B
BSDL-90	176 – 198 (80 – 90)	64 (29)	9.85 (3000)	B
BSDL-100	198 – 220 (90 – 100)	81.1 (36.8)	9.85 (3000)	C
BSDL-115	220 – 254 (100 – 115)	85.3 (38.7)	9.85 (3000)	C
BSDL-130	254 – 286 (115 – 130)	88 (39.9)	9.85 (3000)	C
BSDL-140	286 – 309 (130 – 140)	94.4 (42.8)	9.85 (3000)	C
BSDL-150	309 – 330 (140 – 150)	100.6 (45.6)	9.85 (3000)	C

Higher capacities available upon request.

- ▶ Safety device prevents load dropping
- ▶ Upper suspension with rotary safety hook
- ▶ Precision guided cable winding prevents jamming
- ▶ Anti-friction cable guide
- ▶ Worm screw capacity adjustment
- ▶ Alignable rotating upper hook
- ▶ Cable replacement without balancer disassembly
- ▶ Cable visible for inspection
- ▶ Floor controlled locking device for instant manual clamping or release (BIL-3224)

Rail Profile	Trolley Part Number		
	INTERMEDIATE DUTY	HEAVY DUTY	SUPER DUTY
ZRAT	31057	ZHS31058	ZHS31058
ZRA1	ZHS30304	ZHS30313	ZHS30313
ZRA2	30923	ZHS30314	ZHS30314
ZRS2/3	30842	ZHS30315	ZHS30315

Arm Systems

Great for reaching in, under, and around obstacles to precisely and effortlessly position loads

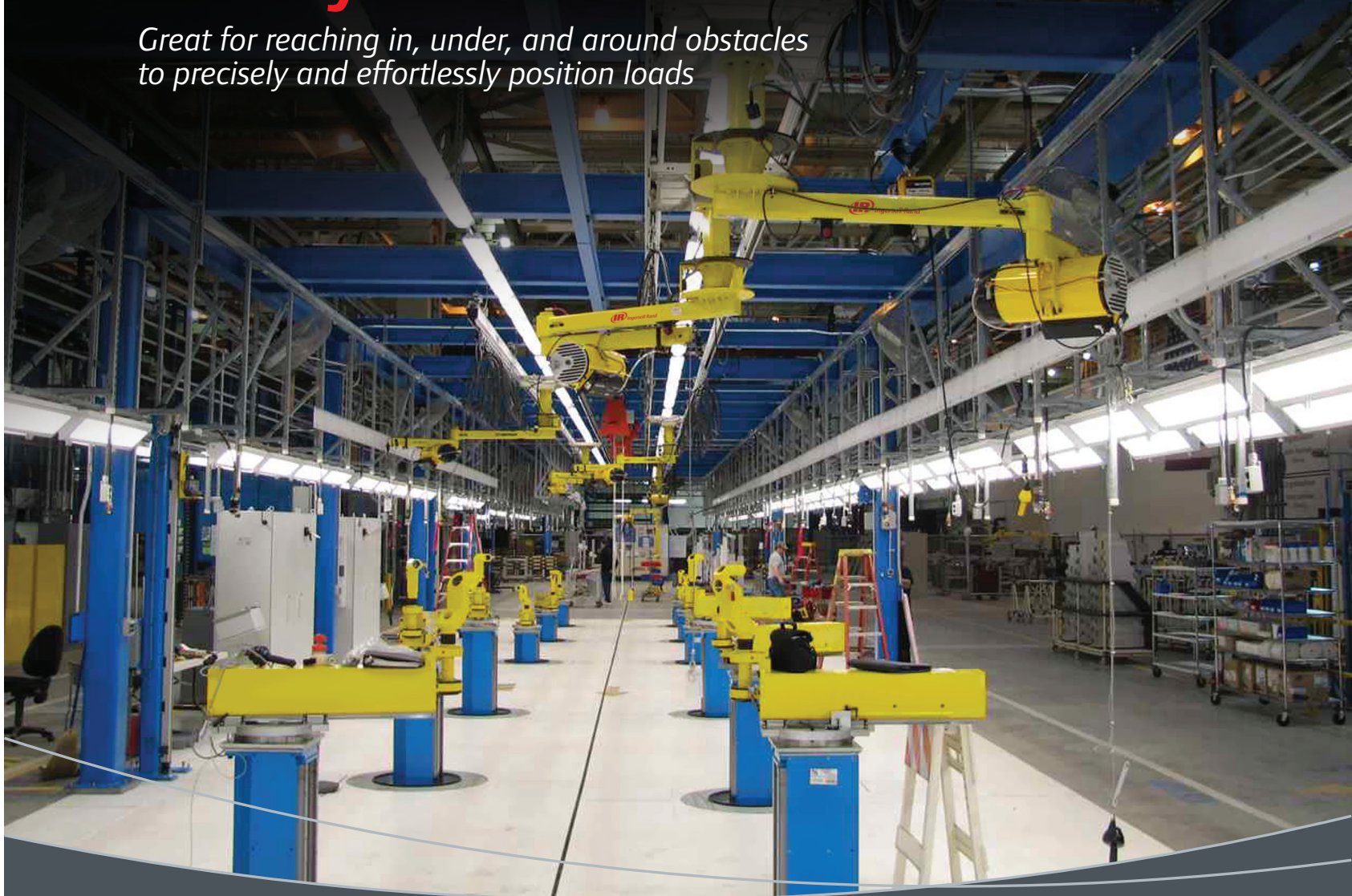

Ingersoll Rand offers:

- ▶ Column or overhead mounting options
- ▶ Three styles: articulating, parallel link, and vertical mast
- ▶ Up to 10 ft of horizontal reach
- ▶ Capacities up to 1,000 lb

Zimmerman Series Arm Systems

The Ingersoll Rand Arm System **ADVANTAGE**

- ▶ **Ergonomic reach** — Prevents the need for operator to bend and reach into tight areas causing injury
- ▶ **Precise, strain-free positioning** — Float leaves both hands free to raise, lower, or shift the load with virtually no resistance
- ▶ **Versatility** — Three styles available to fit a diverse set of applications in nearly any industry
- ▶ **Rugged reliability** — Continuous duty with minimal maintenance
- ▶ **Integrated air supply** — Prevents tangling of air lines running to below-the-hook handling devices

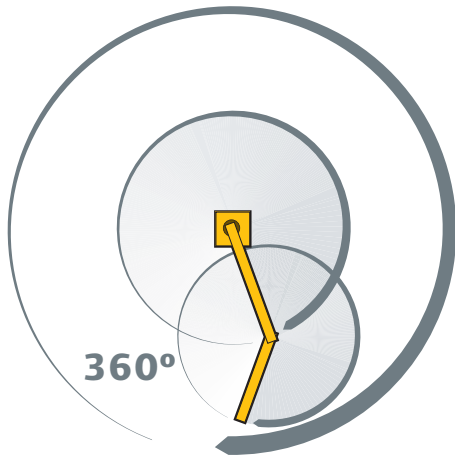

Parallel link arms:

Parallel link arms utilize an air cylinder with a parallel link structure for lifting / lowering, making them ideal for reach-in applications.

Features:

- ▶ Capable of handling offset loads
- ▶ Column or carriage mount
- ▶ Up to 5 ft vertical travel and 800 lb capacity
- ▶ Optional brakes and limit switches available

Note: Parallel link-style arms are designed to specific customer requirements. Contact factory for more information.

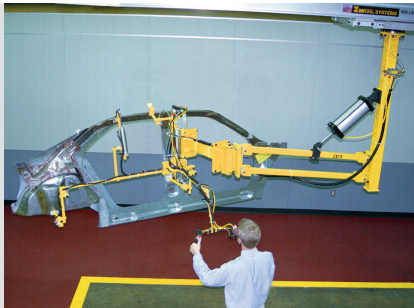

700 Series articulating arms:

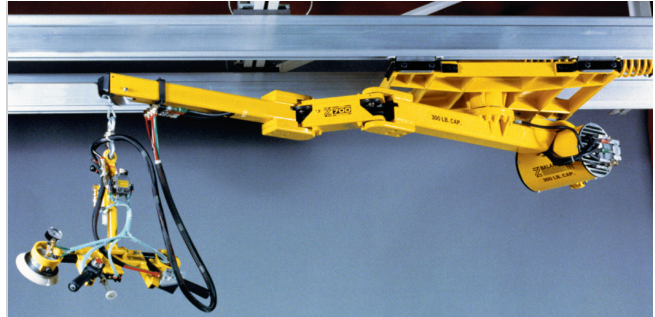

700 Series arms combine the benefits of an air balancer with the flexibility and reach of an articulating arm.

Features:

- ▶ Column, ceiling, or carriage mount
- ▶ Up to 10 ft horizontal reach and 500 lb capacity
- ▶ Includes integrated air balancer available in rear-mount, mid-mount, and front-mount configurations.



600 Series arms:

600 Series arms utilize a rigid mast to guide the lifting / lowering, which is done by an integrated air balancer.

Features:

- ▶ Capable of handling offset loads
- ▶ Carriage mount compatible with most rail systems
- ▶ Up to 8 ft vertical travel and 1,000 lb capacity
- ▶ Includes integrated air balancer



Zimmerman Series Arm Systems

700C Series arm

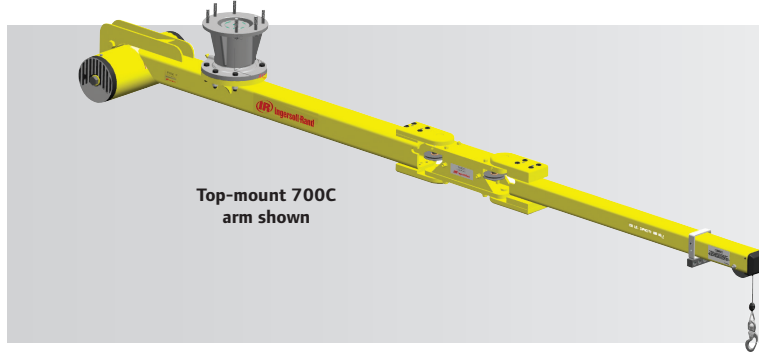

Features:

- ▶ Rear-mount balancer offers lowest rotational inertia of all models
- ▶ Short stack-up for low headroom applications
- ▶ Two-point pivot providing 270° articulation
- ▶ Carriage or column mount
- ▶ Arm lengths of 6, 7, 8, 9, and 10 ft available
- ▶ Integrated 150, 200, 350, or 500 lb balancer

700C Series arm

Base Model	Arm Length ft (m)	Capacity lb (kg)	Weight lb (kg)
70015XXXXXXXX06X	6' (1.83)	150 (65)	218 (99)
70015XXXXXXXX07X	7' (2.13)	150 (65)	237 (108)
70015XXXXXXXX08X	8' (2.44)	150 (65)	248 (113)
70015XXXXXXXX09X	9' (2.74)	150 (65)	263 (120)
70015XXXXXXXX10X	10' (3.05)	150 (65)	275 (125)
70020XXXXXXXX06X	6' (1.83)	200 (90)	248 (113)
70020XXXXXXXX07X	7' (2.13)	200 (90)	267 (121)
70020XXXXXXXX08X	8' (2.44)	200 (90)	278 (126)
70020XXXXXXXX09X	9' (2.74)	200 (90)	278 (126)
70020XXXXXXXX10X	10' (3.05)	200 (90)	304 (138)
70035XXXXXXXX06X	6' (1.83)	350 (155)	257 (117)
70035XXXXXXXX07X	7' (2.13)	350 (155)	279 (127)
70035XXXXXXXX08X	8' (2.44)	350 (155)	290 (132)
70035XXXXXXXX09X	9' (2.74)	350 (155)	290 (132)
70035XXXXXXXX10X	10' (3.05)	350 (155)	316 (144)
70050XXXXXXXX06X	6' (1.83)	500 (225)	271 (123)
70050XXXXXXXX07X	7' (2.13)	500 (225)	290 (132)
70050XXXXXXXX08X	8' (2.44)	500 (225)	328 (149)
70050XXXXXXXX09X	9' (2.74)	500 (225)	350 (159)
70050XXXXXXXX10X	10' (3.05)	500 (225)	367 (167)

700C Series arm – dimensions (inches)

Capacity lb								Top Mount		Bottom Mount	
	A	B	C	D	G	J	K	H	L	H	L
150	72	26	34	6.78	4.25	23.75	12	13.25	8	7.75	13.53
150	84	38	34	6.78	4.25	23.75	12	13.25	8	7.75	13.53
150	96	38	46	6.78	4.25	23.75	12	13.25	8	7.75	13.53
150	108	38	46	6.78	4.25	23.75	24	13.25	8	7.75	13.53
150	120	38	46	6.78	4.25	23.75	36	13.25	8	7.75	13.53
200	72	26	34	6.78	4.25	26	12	13.25	11.13	7.75	13.66
200	84	38	34	6.78	4.25	26	12	13.25	11.13	7.75	13.66
200	96	38	46	6.78	4.25	26	12	13.25	11.13	7.75	13.66
200	108	38	46	6.78	4.25	26	24	13.25	11.13	7.75	13.66
200	120	38	46	6.78	4.25	26	36	13.25	11.13	7.75	13.66
350	72	26	34	6.78	4.25	27	12	13.25	9.96	7.75	14.47
350	84	38	34	6.78	4.25	27	12	13.25	9.96	7.75	14.47
350	96	38	46	6.78	4.25	27	12	13.25	9.96	7.75	14.47
350	108	38	46	6.78	4.25	27	24	13.25	9.96	7.75	14.47
350	120	38	46	6.78	4.25	27	36	13.25	9.96	7.75	14.47
500	72	26	34	6.78	4.25	27	12	13.25	10.63	7.75	14.16
500	84	38	34	6.78	4.25	27	12	13.25	10.63	7.75	14.16
500	96	38	46	8.5	5.5	27	12	13.25	11.38	7.75	16.63
500	108	38	46	8.5	5.5	27	24	13.25	11.38	7.75	16.63
500	120	38	46	8.5	5.5	27	36	13.25	11.38	7.75	16.63

Note: See Page 36 – Arm model driver for configuration options, "X" in base model above requires option selection.

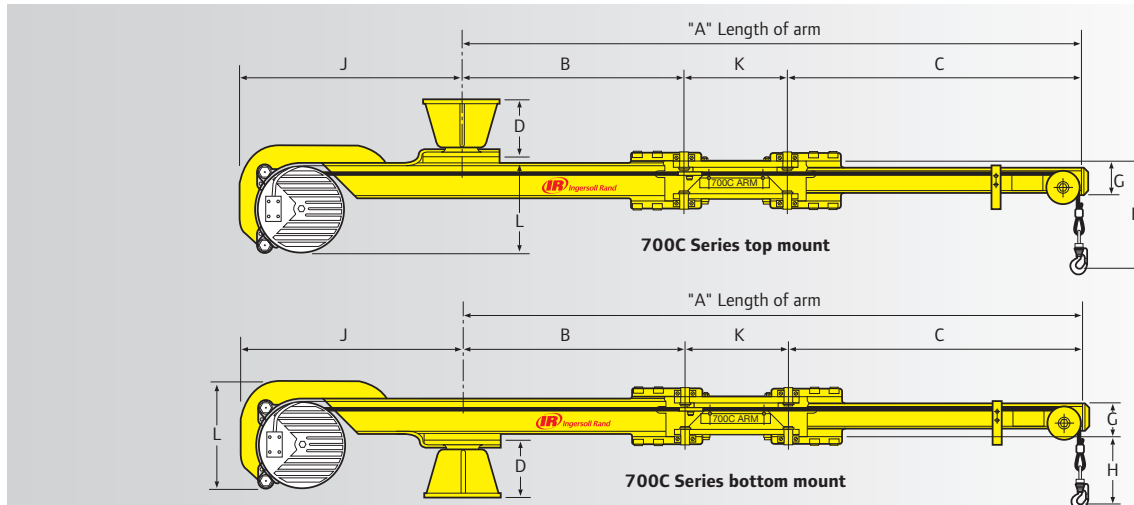

Zimmerman Series Arm Systems

713 Series arm

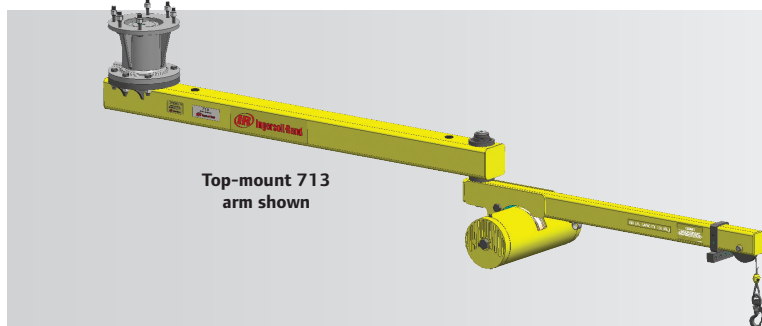

Features:

- ▶ Mid-mount balancer
- ▶ Over-under boom design with single pivot point for 360° articulation
- ▶ Carriage or column mount
- ▶ Arm lengths of 6, 7, 8, 9, and 10 ft available
- ▶ Integrated 150, 200, 350, or 500 lb balancer

713 Series arm

Base Model	Arm Length ft (m)	Capacity lb (kg)	Weight lb (kg)
71315XXXXXXXX06X	6' (1.83)	150 (65)	151 (69)
71315XXXXXXXX07X	7' (2.13)	150 (65)	166 (75)
71315XXXXXXXX08X	8' (2.44)	150 (65)	175 (80)
71315XXXXXXXX09X	9' (2.74)	150 (65)	184 (84)
71315XXXXXXXX10X	10' (3.05)	150 (65)	228 (104)
71320XXXXXXXX06X	6' (1.83)	200 (90)	197 (90)
71320XXXXXXXX07X	7' (2.13)	200 (90)	213 (97)
71320XXXXXXXX08X	8' (2.44)	200 (90)	224 (102)
71320XXXXXXXX09X	9' (2.74)	200 (90)	235 (107)
71320XXXXXXXX10X	10' (3.05)	200 (90)	281 (128)
71335XXXXXXXX06X	6' (1.83)	350 (155)	233 (106)
71335XXXXXXXX07X	7' (2.13)	350 (155)	246 (112)
71335XXXXXXXX08X	8' (2.44)	350 (155)	261 (119)
71335XXXXXXXX09X	9' (2.74)	350 (155)	258 (117)
71335XXXXXXXX10X	10' (3.05)	350 (155)	271 (123)
71350XXXXXXXX06X	6' (1.83)	500 (225)	261 (119)
71350XXXXXXXX07X	7' (2.13)	500 (225)	275 (125)
71350XXXXXXXX08X	8' (2.44)	500 (225)	276 (125)
71350XXXXXXXX09X	9' (2.74)	500 (225)	335 (152)
71350XXXXXXXX10X	10' (3.05)	500 (225)	351 (160)

713 Series arm – dimensions (inches)

Capacity lb									Top Mount		Bottom Mount	
	A	B	C	D	F	G	H	E	K	E	K	
150	72	41	31	6.78	9.19	3	10	5.46	3	4.75	8.5	
150	84	47	37	6.78	9.19	3	10	5.46	3	4.75	8.5	
150	96	53	43	6.78	9.19	3	10	5.46	3	4.75	8.5	
150	108	59	49	6.78	9.19	3	10	5.46	3	4.75	8.5	
150	120	65	55	6.78	9.19	3	10	5.46	3	4.75	8.5	
200	72	41	31	6.78	12.81	4	9	5.46	3	4.75	8.5	
200	84	47	37	6.78	12.81	4	9	5.46	3	4.75	8.5	
200	96	53	43	6.78	12.81	4	9	5.46	3	4.75	8.5	
200	108	59	49	6.78	12.81	4	9	5.46	3	4.75	8.5	
200	120	65	55	6.78	12.81	4	9	5.46	3	4.75	8.5	
350	72	41	31	6.78	12.81	4	9	5.54	3	4.75	8.5	
350	84	47	37	6.78	12.81	4	9	5.54	3	4.75	8.5	
350	96	53	43	6.78	12.81	4	9	5.54	3	4.75	8.5	
350	108	59	49	6.78	12.81	4	9	6.78	3	6	8.5	
350	120	65	55	6.78	12.81	4	9	6.78	3	6	8.5	
500	72	41	31	6.78	12.81	4	9	5.54	3	4.75	8.5	
500	84	47	37	6.78	12.81	4	9	5.54	3	4.75	8.5	
500	96	53	43	8.5	12.81	4	9	6.79	3	6	8.5	
500	108	59	49	8.5	12.81	4	9	6.79	3	6	8.5	
500	120	65	55	8.5	12.81	4	9	6.79	3	6	8.5	

Note: See Page 36 – Arm model driver for configuration options, "X" in base model above requires option selection.

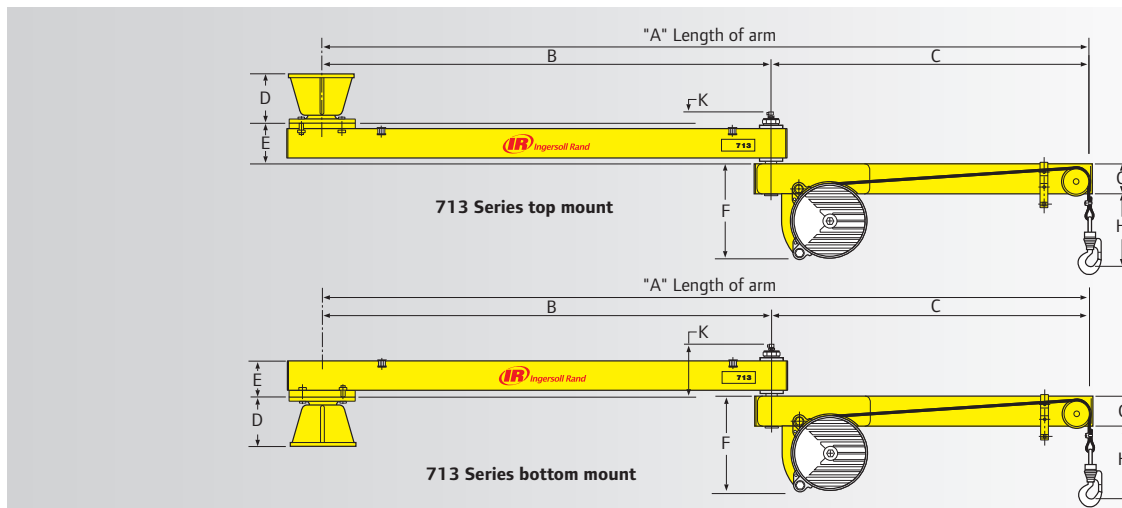

Zimmerman Series Arm Systems

720 Series arm

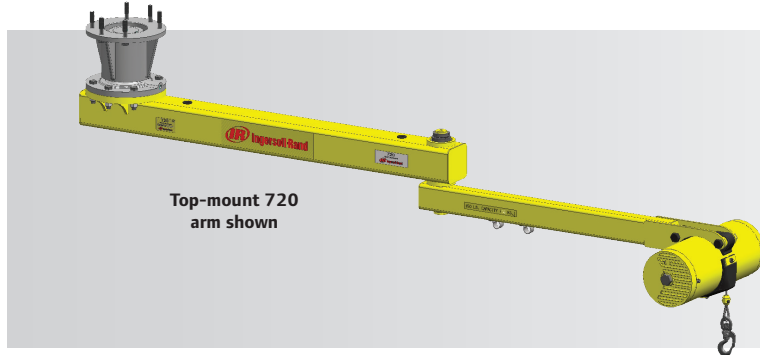

Top-mount 720 arm shown

Features:

- ▶ End-mount balancer
- ▶ Over-under boom design with single pivot point for 360° articulation
- ▶ Carriage or column mount
- ▶ Arm lengths of 6, 7, 8, 9, and 10 ft available
- ▶ Available only in 150 lb capacity

720 Series arm

Base Model	Arm Length ft (m)	Capacity lb (kg)	Weight lb (kg)
72015XXXXXXXX06X	6' (1.83)	150 (65)	218 (99)
72015XXXXXXXX07X	7' (2.13)	150 (65)	237 (108)
72015XXXXXXXX08X	8' (2.44)	150 (65)	248 (113)
72015XXXXXXXX09X	9' (2.74)	150 (65)	263 (120)
72015XXXXXXXX10X	10' (3.05)	150 (65)	275 (125)

720 Series arm – dimensions (inches)

Capacity lb								Top Mount	Bottom Mount
	A	B	C	D	F	G	H	E	E
150	72	41	31	6.78	7.8	3	16.5	5.46	4.75
150	84	47	37	6.78	7.8	3	16.5	5.46	4.75
150	96	53	43	6.78	7.8	3	16.5	5.46	4.75
150	108	59	49	6.78	7.8	3	16.5	5.46	4.75
150	120	65	55	6.78	7.8	3	16.5	5.46	4.75

Note: See Page 36 – Arm model driver for configuration options, "X" in base model above requires option selection.

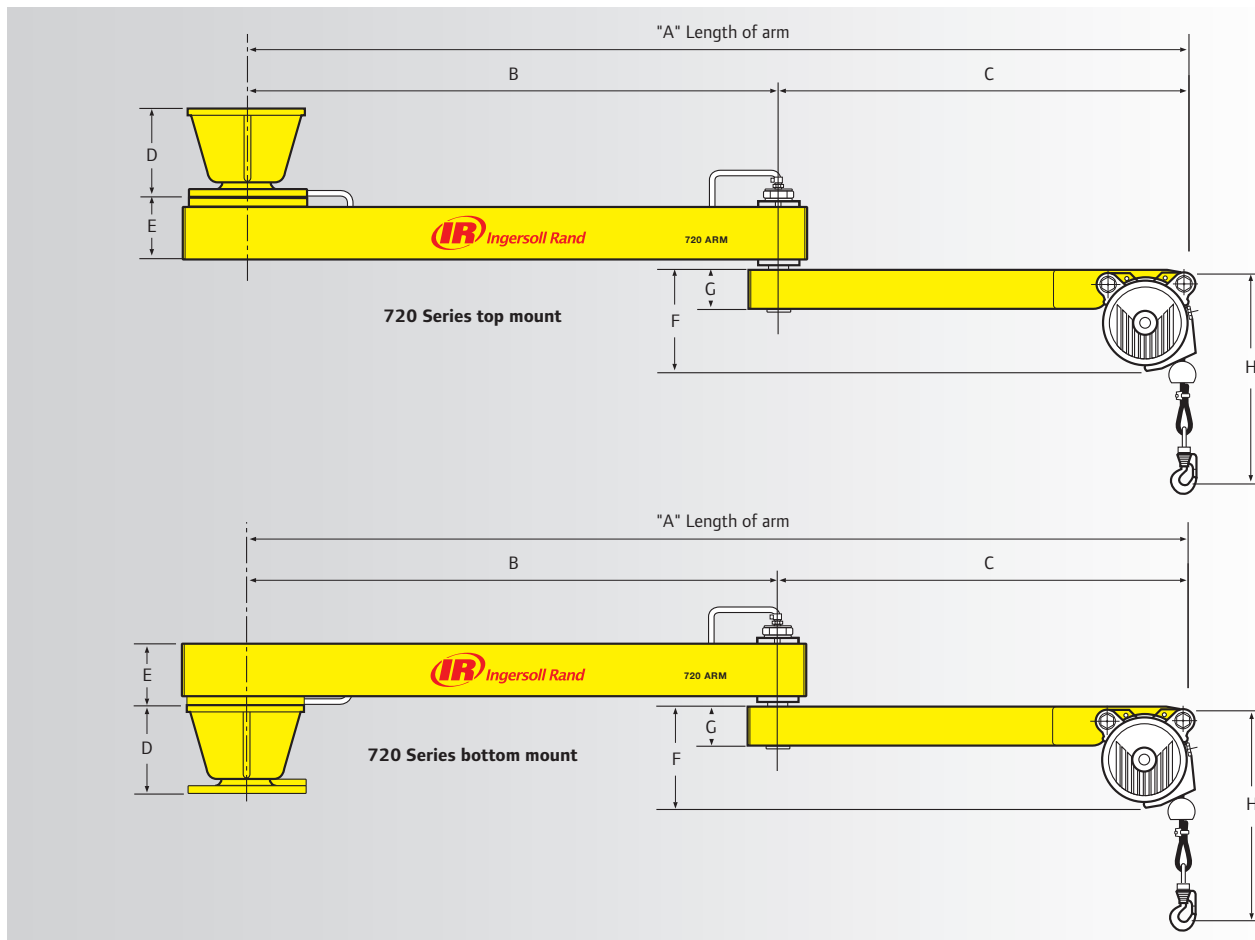

Zimmerman Series Arm Systems

700 Series arm options and accessories

Mounting accessories

Symbol	Description
A	Overhead mount column 13.12 inches tall (for use with ceiling-mounted arms)
B	Column, 8 feet tall
C	Column, 8 feet 6 inches tall
D	Column, 9 feet tall
E	Column, 10 feet tall
F	Column, 11 feet tall
G	Column, 12 feet tall

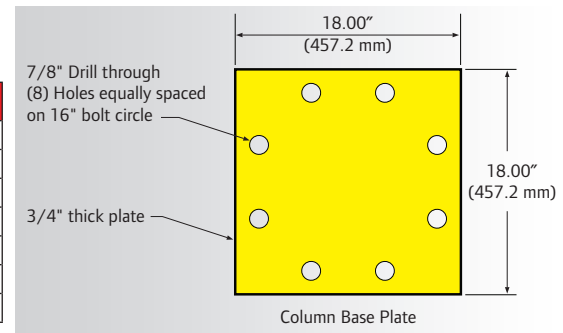

Carriages

Symbol	Description	Part No.
NT	Carriage – basic, no trolleys	40710
TR	Carriage assembly – T-rail / I-beam	40709
A2	Carriage assembly – ZRA2 (reaction trolley)	30028-1
S2	Carriage assembly – ZRS2 / ZRS3	30028-2
A1	Carriage assembly – ZRA1	30028-3
E8	Carriage assembly – ETA-8 (reaction trolley)	30028-4
K2	Carriage assembly – KBK2	30028-5

Note: Lightweight ALMAG casting. Basic carriage weighs 60.0 lb (27.3 kg)

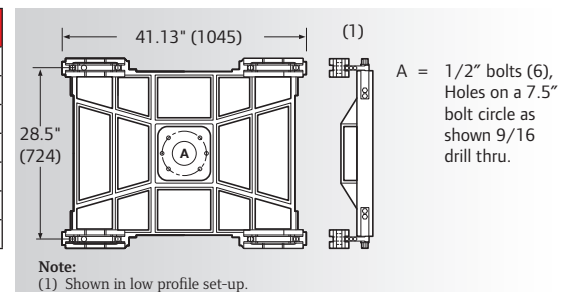

Controls

Symbol	Description
ZP	ZA (Zim-Air) up / down pendant control
ZQ	ZA (Zim-Air) up / down pendant control with Quad-Coil
ZT	ZA (Zim-Air) up / down pendant control with Tri-Coil
BA	BA (Balance-Air), single balance control (only for use on 150 lb capacity units)
BZ	BA (Balance-Air) Z-servo, single balance control
EP	EA (Equi-Air) 2PS pressure, load / no-load balance control for use with clamp devices
EV	EA (Equi-Air) 2PS vacuum, load / no-load balance control for use with vacuum devices

Example: 70015SATT0ZP06A

700 Series Articulating Arm model driver

Style 700	Capacity 15	Balancer Type SA	Mounting Option TT	Carriage Options 0	Controls ZP	Arm Length 06	Mounting Access. A
700	15 = 150 lb (68.2 kg)	SA = Standard balancer	TT = Top mount - Ceiling	0 = No carriage	ZP = ZA pendant control	06 = 6 feet (1.83 m)	0 = No mounting column
713	20 = 200 lb (91 kg)	IA = IntelLIFT balancer (consult factory)	BB = Bottom mount - Column	H = High-profile	ZQ = ZA quad-coil control	07 = 7 feet (2.13 m)	A = 13 in (0.33 m) ceiling mount
720 (150-lb capacity only)	35 = 350 lb (159.1 kg)		NT = Carriage - no trolley	L = Low-profile	ZT = ZA tri-coil control	08 = 8 feet (2.44 m)	B = 8 ft (2.44 m) column
	50 = 500 lb (227.3 kg)		TR = Carriage - T-rail / I-beam		BA = Single balance control	09 = 9 feet (2.74 m)	C = 8.5 ft (2.59 m) column
			A2 = Carriage - ZRA2 (reaction trolley)		BZ = Z-servo balance control	10 = 10 feet (3.05 m)	D = 9 ft (2.74 m) column
			S2 = Carriage - ZRS2 / ZRS3		EP = EA control 2ps pressure		E = 10 ft (3.05 m) column
			A1 = Carriage - ZRA1		EV = EA control 2ps vacuum		F = 11 ft (3.35 m) column
			E8 = Carriage - ETA8 (reaction trolley)				G = 12 ft (3.66 m) column
			K2 = Carriage - KBK2				
			Note: A1 carriage mount option is only available for arms with less than 200 lb (90 kg) capacity and less than 8 ft (2.44 m) arm length.				

Zimmerman Series Arm Systems

600 Series arm

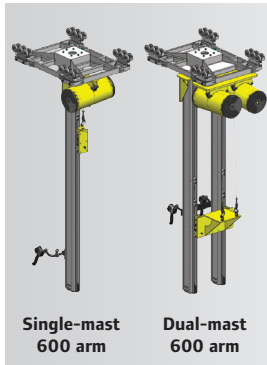

Features:

- ▶ Rigid mast guides load with up to 100 inch travel
- ▶ Accommodates offset loads up to 72 inches from mast
- ▶ 360° Arm rotation
- ▶ Carriage mount for overhead rail system suspension
- ▶ Integrated single, reeved, or tandem balancer to handle up to 1,000 lb

600 Series arm

Base Model	Capacity lb (kg)	Max. Travel in (mm)	Notes
SINGLE MAST CONFIGURATION			
60015XA1XXXXX	150 (68.2)	80 (2032)	1x Balancer
60020XA1XXXXX	200 (90.9)	120 (3048)	1x Balancer
60035XA1XXXXX	350 (159.1)	80 (2032)	1x Balancer
60050XA1XXXXX	500 (227.3)	80 (2032)	1x Balancer
6007RXA1XXXXX	700 (318.2)	40 (1016)	1x Bal. (reeved)
6007TXA1XXXXX	700 (318.2)	80 (2032)	2x Balancer
6001RXA1XXXXX	1,000 (454.5)	40 (1016)	1x Bal. (reeved)
6001TXA1XXXXX	1,000 (454.5)	80 (2032)	2x Balancer
DUAL MAST CONFIGURATION			
60015XA2XXXXX	150 (68.2)	80 (2032)	1x Balancer
60020XA2XXXXX	200 (90.9)	120 (3048)	1x Balancer
60035XA2XXXXX	350 (159.1)	80 (2032)	1x Balancer
60050XA2XXXXX	500 (227.3)	80 (2032)	1x Balancer
6007RXA2XXXXX	700 (318.2)	40 (1016)	1x Bal. (reeved)
6007TXA2XXXXX	700 (318.2)	80 (2032)	2x Balancer
6001RXA2XXXXX	1,000 (454.5)	40 (1016)	1x Bal. (reeved)
6001TXA2XXXXX	1,000 (454.5)	80 (2032)	2x Balancer

Note: See Page 38 – Arm model driver for configuration options. Note: "X" in base model above requires option selection.

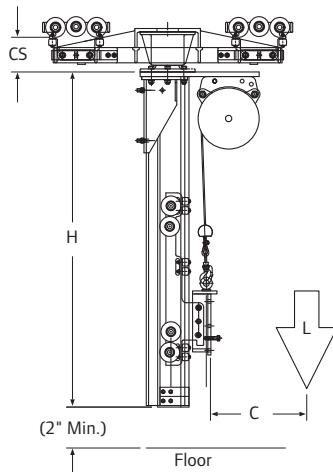

600 Series arm - allowable mast configurations

Load (L) max lb (kg)	Load CG (C) max in (mm)	Mast Ht. (H) max in (mm)	Max Hook Travel in (mm)	
SINGLE MAST CONFIGURATION				
150 (68.2)	12 (305)	144 (3658)	80 (2032)	
	24 (610)	144 (3658)	80 (2032)	
	36 (914)	144 (3658)	80 (2032)	
	48 (1219)	144 (3658)	80 (2032)	
	60 (1524)	138 (3505)	80 (2032)	
	72 (1829)	114 (2896)	74 (1880)	
	200 (90.9)	12 (305)	144 (3658)	104 (2642)
		24 (610)	144 (3658)	104 (2642)
36 (914)		144 (3658)	104 (2642)	
48 (1219)		126 (3200)	86 (2184)	
60 (1524)		102 (2591)	62 (1575)	
72 (1829)		84 (2134)	44 (1118)	
350 (159.1)		12 (305)	144 (3658)	80 (2032)
		24 (610)	144 (3658)	80 (2032)
	36 (914)	96 (2438)	56 (1422)	
	48 (1219)	72 (1829)	32 (813)	
	60 (1524)	60 (1524)	20 (508)	
	72 (1829)	48 (1219)	8 (203)	
	500 (227.3)	12 (305)	144 (3658)	80 (2032)
		24 (610)	102 (2591)	62 (1575)
36 (914)		66 (1676)	26 (660)	
48 (1219)		54 (1372)	14 (356)	
700 (318.2)		12 (305)	138 (3505)	40/80 (1016/2032)
		24 (610)	72 (1829)	26/32 (660/813)
		36 (914)	48 (1219)	2/8 (51/203)
1000 (454.5)		12 (305)	96 (2438)	40/56 (1016/1422)
	24 (610)	54 (1372)	8/14 (203/356)	
	DUAL MAST CONFIGURATION			
150 (68.2)	60 (1524)	144 (3658)	80 (2032)	
	72 (1829)	144 (3658)	80 (2032)	
	200 (90.9)	48 (1219)	144 (3658)	104 (2642)
60 (1524)		144 (3658)	104 (2642)	
72 (1829)		144 (3658)	104 (2642)	
350 (159.1)	36 (914)	144 (3658)	80 (2032)	
	48 (1219)	144 (3658)	80 (2032)	
	60 (1524)	120 (3048)	80 (2032)	
500 (227.3)	72 (1829)	102 (2591)	62 (1575)	
	24 (610)	144 (3658)	80 (2032)	
	36 (914)	144 (3658)	80 (2032)	
700 (318.2)	48 (1219)	144 (3658)	80 (2032)	
	12 (305)	144 (3658)	40/80 (1016/2032)	
	24 (610)	144 (3658)	40/80 (1016/2032)	
1000 (454.5)	36 (914)	102 (2591)	40/62 (1016/1575)	
	12 (305)	144 (3658)	40/80 (1016/2032)	
	24 (610)	108 (2743)	40/68 (1016/1727)	

Zimmerman Series Arm Systems

600 Series arm options and accessories

Masts

Symbol	Description	Part No.
A	ZRA2 mast, 4' (1.22 m) Long	30000-040-2
B	ZRA2 mast, 4' 6" (1.37 m) Long	30000-045-2
C	ZRA2 mast, 5' (1.52 m) Long	30000-050-2
D	ZRA2 mast, 5' 6" (1.68 m) Long	30000-055-2
E	ZRA2 mast, 6' (1.83 m) Long	30000-060-2
F	ZRA2 mast, 6' 6" (1.98 m) Long	30000-065-2
G	ZRA2 mast, 7' (2.13 m) Long	30000-070-2
H	ZRA2 mast, 7' 6" (2.29 m) Long	30000-075-2
J	ZRA2 mast, 8' (2.44 m) Long	30000-080-2
K	ZRA2 mast, 8' 6" (2.59 m) Long	30000-085-2
M	ZRA2 mast, 9' (2.74 m) Long	30000-090-2
N	ZRA2 mast, 9' 6" (2.90 m) Long	30000-095-2
P	ZRA2 mast, 10' (3.05 m) Long	30000-100-2
Q	ZRA2 mast, 10' 6" (3.20 m) Long	30000-105-2
R	ZRA2 mast, 11' (3.35 m) Long	30000-110-2
S	ZRA2 mast, 11' 6" (3.51 m) Long	30000-115-2
T	ZRA2 mast, 12' (3.66 m) Long	30000-120-2

Carriages

Symbol	Description	Stack-up ⁽¹⁾ (CS)	Part No.
NT	Carriage - basic, no trolleys	-	40710
TR	Carriage - T-rail / I-beam	5.46	40709
A2	Carriage - ZRA2 (reaction trolley)	5.97	30028-1
S2	Carriage - ZRS2 / ZRS3	5.97	30028-2
A1	Carriage - ZRA1	8.44	30028-3
E8	Carriage - ETA-8 (reaction trolley)	7.16	30028-4
K2	Carriage - KBK2	5.97	30028-5

Note: Lightweight ALMAG casting. Carriage weighs 60.0 lb (27.3 kg)

(1) Dimension is from the rail running surface to the base of the pivot. Changes with brake option.

Controls

Symbol	Description	Controls Subassembly No.	
		1x Mast	2x Mast
Z	ZA (Zim-Air) up / down pendant control	54039847	54039854

Brake options

Symbol	Description	Part No.
0	No brake	-
P	Pin-lock brake (hard stops every 45 degrees)	54039722
B	Bumper friction brake	54039730
C	Caliper brake	54040977

Example: 60015SA1A2ZPG

600 Series Arm model driver

Style 600	Capacity - Vertical Travel 15	Balancer Type SA	Single or Dual Mast 1	Carriage Option A2	Controls Z	Brake Options P	Mast Length G
600	15 = 150 lb (68.2 kg) - 80 in (2032 mm) 20 = 200 lb (90.9 kg) - 120 in (3048 mm) 35 = 350 lb (159.1 kg) - 80 in (2032 mm) 50 = 500 lb (227.3 kg) - 80 in (2032 mm) 7R = 700 lb (318.2 kg) - 40 in (1016 mm) 7T = 700 lb (318.2 kg) - 80 in (2032 mm) 1R = 1000 lb (454.5 kg) - 40 in (1016 mm) 1T = 1000 lb (454.5 kg) - 80 in (2032 mm)	SA = Standard balancer IA = IntelLIFT balancer (consult factory)	1 = single mast 2 = dual mast	A1 = Carriage - ZRA1 A2 = Carriage - ZRA2 (reaction trolley) S2 = Carriage - ZRS2 S3 = Carriage - ZRS3 TR = T-Rail / I-Beam E8 = Carriage - ETA8 (reaction trolley) K2 = Carriage - KBK22	Z = ZA pendant control (includes dummy handle)	0 = No brake P = Pin-lock brake (hard stops every 45 degrees) B = Bumper friction brake (soft stop at any point on 360 degree rotation) C = Caliper brake	A = 4 ft (1.22 m) B = 4 ft 6 in (1.37 m) C = 5 ft (1.52 m) D = 5 ft 6 in (1.68 m) E = 6 ft (1.83 m) F = 6 ft 6 in (1.98 m) G = 7 ft (2.13 m) H = 7 ft 6 in (2.29 m) J = 8 ft (2.44 m) K = 8 ft 6 in (2.59 m) M = 9 ft (2.59 m) N = 9 ft 6 in (2.90 m) P = 10 ft (3.05 m) Q = 10 ft 6 in (3.20 m) R = 11 ft (3.35 m) S = 11 ft 6 in (3.51 m) T = 12 ft (3.66 m)
	Note: R = Reeved balancer T = Tandem balancer			Note: All Ingersoll Rand 600 arms use a low profile carriage.			

Hoists

Industrial lifting equipment



Ingersoll Rand offers:

- ▶ Quantum electric chain hoists
- ▶ Air chain hoists

Quantum Series Electric Hoists

1/8 to 1 metric ton lifting capacities

The Ingersoll Rand Quantum Electric Hoist **ADVANTAGE**

- ▶ **Smooth, quiet operation** — Helical / spur gear combination provides grab-free movement and quiet, reliable operation. A floating chain guide precisely feeds chain onto a machined-matched, five-pocket chain wheel. This system ensures smooth, jam-resistant operation.
- ▶ **Durability** — Quantum load chains are precision-formed from alloy steel, case hardened and zinc-plated. The plating is an Ingersoll Rand proprietary process that resists corrosion better than any standard plating offered for load chain.
- ▶ **Reliability** — With high starting torque, Quantum motors utilize a totally enclosed non-ventilated (TENV) squirrel cage design. The H4-duty classification allows for 300 starts and 30 minutes “on-time” per hour. Class F insulation provides a total thermal rating of 145°C at a 1.0 service factor, instead of the more common Class B insulation of 120°C.
- ▶ **Safety** — State-of-the-art AC motor brakes with all-steel discs. Multiple stacking significantly increases braking surface area, reducing wear and extending life. Quantum brake discs are guaranteed for the life of the hoist. The overload clutch is factory-set to limit Quantum from lifting loads in excess of 150% of rated hoisting capacity.
- ▶ **Ergonomics** — Safety-first pendant control handles are comfortable and fit securely in the operator’s hand. Each low-voltage (42-volt) control handle integrates a large, red emergency stop button. Operating buttons are clearly marked with high contrast arrows, feature soft-push action, and are horizontally aligned for easier operation.

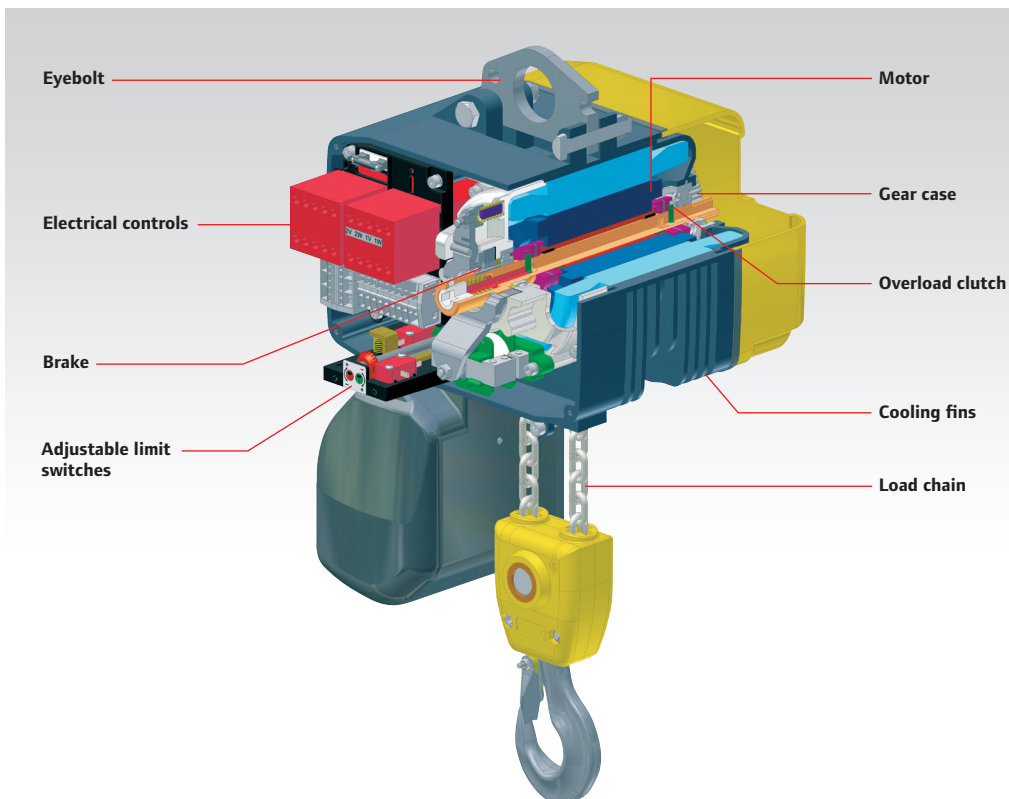

Quantum Series Electric Hoists

1/8 to 1 metric ton lifting capacities

Quantum Series pendant control:

Handy Handle control

This ergonomically designed control enables precise operation at the hook and acts as a robotic power extension of the operator's arm. The load can be positioned and controlled with one hand, freeing the other to position the load. The Handy Handle can be ordered separately as part of a kit, to convert any 1/8-, 1/4-, and 1/2-ton single-line Quantum hoist, or as an "H" control option on a new hoist. Each Handy Handle comes standard with single- or dual-speed thumb control lever switches and red emergency stop button. A socket connection at the bottom allows the standard hook to be easily replaced by custom-end effectors or grabs.



Standard ergonomic "Charlie" pendant

Pendant features horizontal two-speed switch button for up and down hoist operations.



Quantum models

Model	Capacity Metric Tons	Chain Falls	Lift Speed fpm	Motor HP	Amperage			Weight* lb
					230V	460V	575V	
THREE-PHASE (SINGLE-SPEED)								
QCH50-1NS12	1/8	1	32	1	3.5	1.8	1.4	45
QCH50-1NS25	1/4	1	32	1	3.5	1.8	1.4	45
QCH50-1NS50	1/2	1	32	1	3.5	1.8	1.4	45
QCH50-2NS100	1	2	16	1	3.5	1.8	1.4	50
QCH100-1NS100	1	1	32	2.1	7.4	3.7	3.0	100
THREE-PHASE (DUAL-SPEED)								
QCH50-1ND12	1/8	1	32 / 8	1	3.5	1.8	1.4	50
QCH50-1ND25	1/4	1	32 / 8	1	3.5	1.8	1.4	50
QCH50-1HD25	1/4	1	50 / 12	1	3.5	1.8	1.4	50
QCH50-1ND50	1/2	1	32 / 8	1	3.5	1.8	1.4	50
QCH50-2ND100	1	2	16 / 4	1	3.5	1.8	1.4	55
QCH100-1ND100	1	1	32 / 8	2.1	8.0	4.0	3.2	101

Multiply speeds shown by 0.83 for 380-volt / 50 Hz units.
*All weights listed are with standard 10 ft of lift and 6 ft of pendant drop

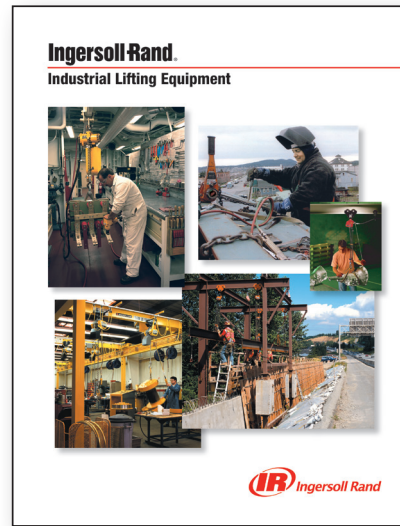

Industrial Lifting Catalog: Form No. MHD55003 available online at irtools.com/lifting

Example: QCH100-1NS100H-21-17-4C

Quantum Hoists model driver

Base Model	Suspension	Lift (ft)	Pendant Drop (ft)	Voltage	Options
QCH100-1NS100	H	21	17	4	C
<i>See model tables above for available models</i>	E = Eye bolt H = Hook	10 = Standard 15 = Standard 20 = Standard xx = Specify length	6 = Standard 11 = Standard 16 = Standard xx = Specify length	3 = 230/3/360 4 = 460/4/60 5 = 575/3/60 6 = 380/3/50*	C = Chain container E = External strain relief F = XX, specify power cord length (standard is 15 ft) H = Handy Handle K = 110 volt control P = Pendant with vertical aligned buttons P2 = Pendant with 2 extra vertical aligned buttons P4 = Pendant with 4 extra vertical aligned buttons Y = Bullard top hook Z = Bullard bottom hook
Note: Additional options and capacities available. Refer to Industrial Lifting Catalog: Form No. MHD55003 available online at irtools.com/lifting					

MLK Series Air Hoists

1/4 to 1 metric ton lifting capacities

The Ingersoll Rand MLK Air Hoist **ADVANTAGE**

- ▶ **Continuous operation** — Suitable for A5 / H5 severe-duty use in the 1/4 to 1 metric ton range. Designed to be used as a high-speed production hoist
- ▶ **Precision spotting** — Precision throttle valves for smooth operation and metering of air combined with control adjustment screws to provide sensitivity and maximum speed control for pendant models. For even more precise control, MLKS slow-speed models are available
- ▶ **Interchangeable** — Motor, brake, and throttle parts are interchangeable with all current Ingersoll Rand air chain hoists making repair and maintenance easier
- ▶ **Durability** — Heat-treated planetary gearing system provides high-torque capability by splitting the torque path, thereby dividing and balancing the load over more teeth, assuring longer life and reduced maintenance

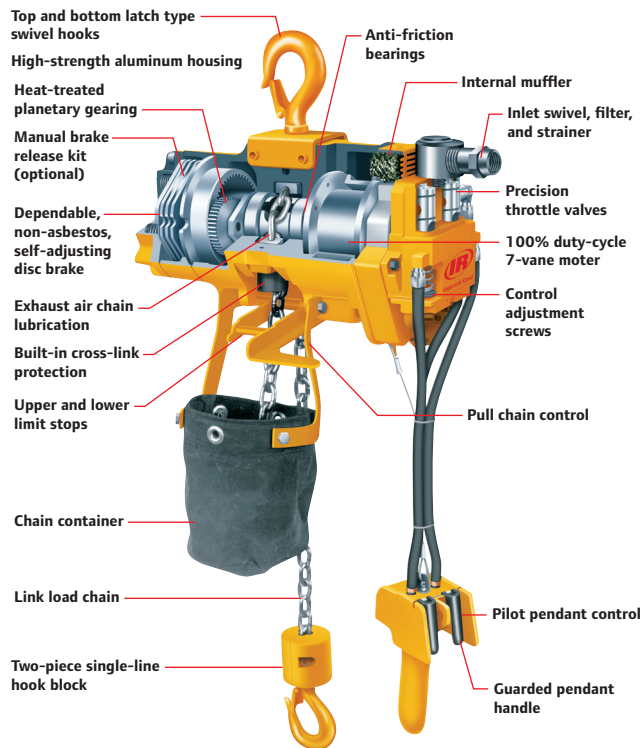

MLK models

Model	Capacity		Number of chain falls	Weight per foot of lift lb	Weight lb
	Metric tons	lb			
ML250K	1/4	550	1	0.56	48
ML500K	1/2	1,100	1	0.56	48
ML1000K	1	2,200	2	1.12	61

*All weights listed are with standard 10 ft of lift and 6 ft of pendant drop

Hoist operating data @ 90 psi

Series	Rated Load		Half Load		No Load	
	Up fpm	Down fpm	Up fpm	Down fpm	Up fpm	Down fpm
MLK Series						
ML250K	101	117	145	111	171	99
ML500K	55	97	80	72	106	59
ML1000K	28	49	40	36	53	30

Example: ML500K-2C10-C6U

MLK Hoists model driver

Series M	Chain L	Capacity 500K	Control 2	Suspension C	Lift (ft) 10	Lower Hook C	Pendant Length 6	Options U
M = Series	L = Link chain	250K = 250 kg/550 lb 500K = 500 kg/1100 lb 1000K = 1000 kg/2200 lb	0 = No controls 1 = Pull chain 2 = Pendant	A = Fixed lug hook B = Bullard hook C = Swivel hook CP = Copper-plated hook	10 = 10 ft standard XX = Specify length	C = Steel snap hook CP = Copper-plated hook B = Bullard, self-closing hook	6 = 6 ft standard XX = Specify length	M = Manual brake release kit P = Piped-away exhaust S = Steel chain container U = Fabric chain container
Note: Additional options and capacities available. Refer to Industrial Lifting Catalog: Form No. MHD55003 available online at irtools.com/lifting								

ARO Series Air Hoists

1/8 to 1 metric ton lifting capacities

The Ingersoll Rand ARO Air Hoist **ADVANTAGE**

- ▶ **Fast, efficient load handling** — Rotary-vane air motors and efficient gearing combine to deliver one of the fastest lift speeds available. Gear ratios have been calculated to yield the lowest possible air consumption
- ▶ **Continuous, heavy-duty applications** — Simple, rugged, and reliable, these hoists are constructed with few moving parts for easy repair and less downtime
- ▶ **Clean and quiet** — For applications and environments that require clean air, exhaust can be piped away. A two-stage filtration system removes foreign matter from air supplies so motors can operate at peak performance with longer operating lives
- ▶ **Easy installation** — Lightweight and convenient, Ingersoll Rand / ARO hoists are easier to install than any other model. Even in small, confined areas, they can be installed and removed with minimal effort

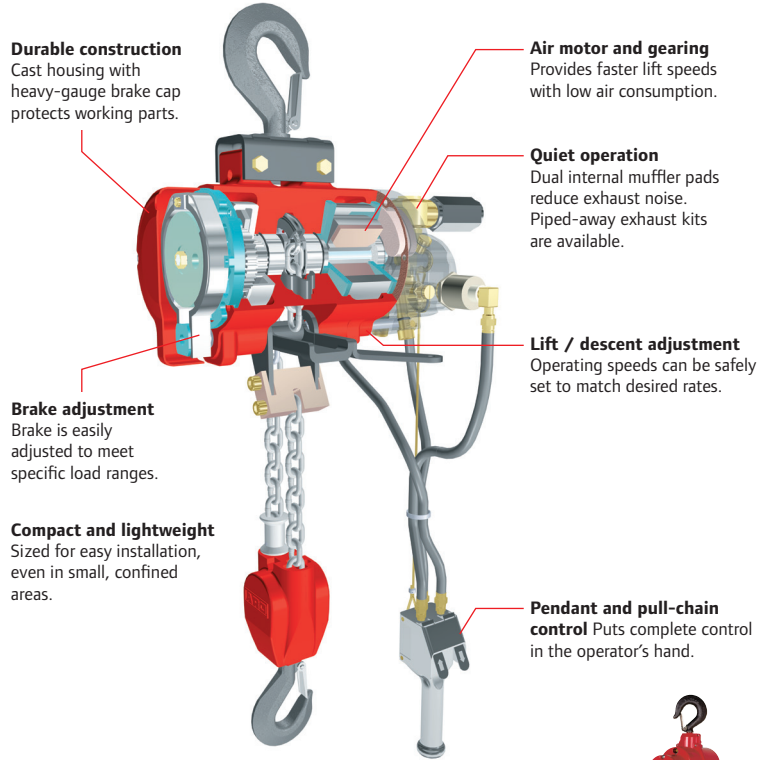

ARO model specifications

	Model					
	7770E	7718E	7756E	7776E	7790A	7740B
Capacity — metric tons (unless otherwise noted)	1/8	1/4	1/2	1	1	300 lbs
Chain falls	1	1	1	2	1	1
Lifting speed range with rated load variable — fpm	20 — 110	28 — 82	14 — 41	7 — 21	4 — 26	1 — 16
Lowering speed range with rated load variable — fpm	140 — 275	120 — 224	60 — 112	30 — 56	5 — 44	1 — 17
Air pressure — psi	90	90	90	90	90	60 — 100
Air consumption @ max rated load — scfm	65 — 70	65 — 70	65 — 70	65 — 70	65 — 70	28
Air inlet size with 180° swivel — in	1/2" NPT (F)	1/2" NPT (F)	1/2" NPT (F)	1/2" NPT (F)	1/2" NPT (F)	1/4" NPT
Recommended hose size — in	1/2" ID	1/2" ID	1/2" ID	1/2" ID	1/2" ID	3/8" ID
Chain basket	Canvas / metal	Canvas / metal	Canvas / metal	Canvas / metal	Canvas / metal	Canvas / metal
Load chain size, link diameter / pitch — in	0.25" / 0.75"	0.25" / 0.75"	0.25" / 0.75"	0.25" / 0.75"	0.312" / 0.858"	0.157" / 0.471"
Weight with pull chain — lb	36	36	36	48	57	15.25
Weight with pendant — lb	41	41	41	53	62	N/A



Example: 7770E-2C-10-C6U

ARO Hoists model driver

Base Model 7770E	Control 2	Upper Suspension C	Lift (ft) 10	Lower Hook C	Control Length (ft) 6	Options U
7740B = 300 lbs 7770E = 1/8 ton 7718E = 1/4 ton 7756E = 1/2 ton 7776E = 1 ton 7790E = 1 ton	0 = No controls* 1 = Pull chain 2 = Pendant*	A = Lug / adapter* C = Steel snap hook K = Bullard hook, manual close	10 = 10 ft standard XX = Specify length	C = Steel snap hook K = Bullard hook, manual close G = Self-latching hook ¹	6 = 6 ft standard XX = Specify length	P = Piped exhaust kit* U = Canvas chain container S = Steel chain container*
Note: Additional options and capacities available. Refer to Industrial Lifting Catalog (Form No. MHD55003) available online at irtools.com/lifting .						

*Not available with 7740B model

Handling Devices

Made for the interaction of man and machine



Ingersoll Rand offers:

- ▶ Standard and custom solutions
- ▶ Manual and powered tilt and rotation packages
- ▶ Innovative designs from the simplest to the most complex device

Zimmerman Series Handling Devices

The Ingersoll Rand Handling Device **ADVANTAGE**

- ▶ **Safety** — Most Ingersoll Rand handling devices come equipped with a safety interlock system that will not allow the operator to accidentally disengage the part during transfer
- ▶ **Ergonomics** — Handling devices can be designed with manual or powered tilt and rotation packages, which allow the operator to orient the part to the proper position with minimal effort
- ▶ **Flexibility** — Through a variety of pneumatic packages, each system is matched to a control package that is tailored to the lifting and positioning task



Standard 4-cup vacuum handling device:



- ▶ Safety Interlock prevents accidental release of load
- ▶ Improve productivity through effective box or flat part pickup, orientation, transfer, and positioning
- ▶ Adjustable handle and controls reduce operator fatigue
- ▶ Protects surface quality with positive secure vacuum gripping and setdown
- ▶ Gives operator complete control throughout the handling operation

Part Number	Cup Centerline Dimensions	Lift Capacity		Cup Diameter
		Vacuum - in Hg	@ 100 psi	
87306338	5" x 7" (127 mm x 178 mm)	6 (porous)	45 lb (20.4 kg)	3" (76 mm)
		18	99 lb (44.9 kg)	3" (76 mm)
		25 (non-porous)	120 lb (54.4 kg)	3" (76 mm)
87306486	10" x 14" (254 mm X 356 mm)	6 (porous)	45 lb (20.4 kg)	3" (76 mm)
		18	99 lb (44.9 kg)	3" (76 mm)
		25 (non-porous)	120 lb (54.4 kg)	3" (76 mm)

To be used with "BW" series pneumatic balancers. Alternate layout and vacuum cup sizes available on request.
Note: Vacuum cups require a flat, non-porous surface. Consult factory for applications with porous surfaces.

Zimmerman Series Handling Devices

Signature bundle handlers

- ▶ Designed to meet the needs of the printing industry in handling logs from 22" – 48" and up to 250 lb
- ▶ Single (10" stroke) and dual (30" stroke) air cylinders with 900 lb clamping force at 90 psi
- ▶ Safety interlock prevents accidental release of load
- ▶ Standard paddles for end boards up to 12" x 12" (extended paddle configurations available — contact factory)
- ▶ Power rotation and self-leveling packages available — contact factory for further information
- ▶ Lightweight aluminum construction

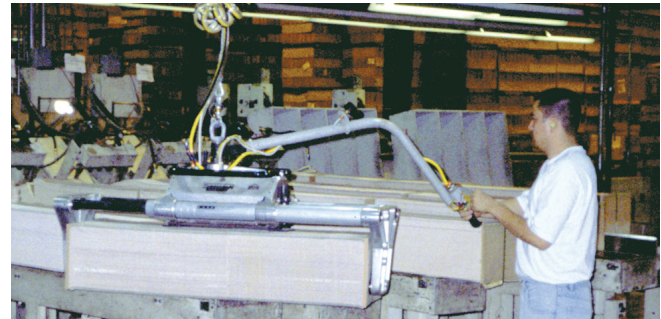

Single cylinder with top swivel handle control



Dual cylinder with top swivel handle control

Part No.	Body Style	Control	Bundle Size in (mm)	Stroke in (mm)
SBH1-1-1	Single cylinder	Single side control	24-32 (610-813)	10 (254)
SBH1-2-1	Single cylinder	Dual side control	24-32 (610-813)	10 (254)
SBH1-3-1	Single cylinder	End control	24-32 (610-813)	10 (254)
SBH1-4-1	Single cylinder	Side and end control	24-32 (610-813)	10 (254)
SBH1-5-1	Single cylinder	Top swivel handle control	24-32 (610-813)	10 (254)
SBH1-1-2	Single cylinder	Single side control	32-40 (813-1016)	10 (254)
SBH1-2-2	Single cylinder	Dual side control	32-40 (813-1016)	10 (254)
SBH1-3-2	Single cylinder	End control	32-40 (813-1016)	10 (254)
SBH1-4-2	Single cylinder	Side and end control	32-40 (813-1016)	10 (254)
SBH1-5-2	Single cylinder	Top swivel handle control	32-40 (813-1016)	10 (254)
SBH1-1-3	Single cylinder	Single side control	40-48 (1016-1219)	10 (254)
SBH1-2-3	Single cylinder	Dual side control	40-48 (1016-1219)	10 (254)
SBH1-3-3	Single cylinder	End control	40-48 (1016-1219)	10 (254)
SBH1-4-3	Single cylinder	Side and end control	40-48 (1016-1219)	10 (254)
SBH1-5-3	Single cylinder	Top swivel handle control	40-48 (1016-1219)	10 (254)

Consult factory for applications that require greater than 10" stroke, dual cylinder available.



Dual cylinder with side control

Zimmerman Series Handling Devices

Rotary action handlers

- ▶ Provides effortless 90-degree manual rotation of rolls up to 300 lb
- ▶ Non-destructive rubber band style as well as pin style noses engage the ID of the core
- ▶ Safety interlock prevents accidental release of load
- ▶ Offered in both lightweight aluminum and rugged steel construction
- ▶ Integrated up/down controls work seamlessly with Ingersoll Rand Pneumatic Balancer



Effortless horizontal to vertical rotation

Body selection chart

Body Material	Capacity lb (kg)	Max Core Length in (mm)	Max Core O.D. in (mm)
Aluminum	100 (45.4)	12 (305)	30 (762)
Steel	300 (136.1)	24 (310)	42 (1067)

Nose selection chart

Nose Style	Capacity lb (kg)
3 Pin	100 (45.4)
6 Pin	300 (136.1)
Single band	200 (90.7)
Double band	300 (136.1)



Custom power tilt

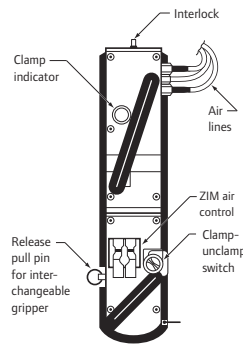
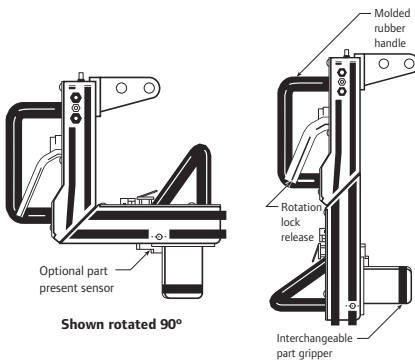

Other options available upon request:

- ▶ Stepped nose for multiple cores
- ▶ "V" groove for pin cart applications
- ▶ Special paint / plating
- ▶ Spindle end locator
- ▶ Adjustable bail
- ▶ Heavy duty pivot for steel rotary action handler offers capacity up to 450 lb

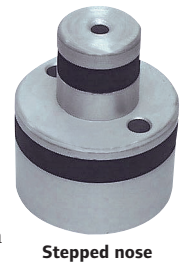

Example: RAHA020030TP

Rotary Action Handler model driver

Device Type RAH	Body Material A	Core ID 020		Core Length 030		Nose Style T	Options P
RAH = Rotary Action Handler	A = Aluminum S = Steel	020 = 2"	075 = 75 mm	030 = 3"	070 = 7"	T = 3 Pin	P = Part present
		030 = 3"	094 = 94 mm	035 = 3.5"	075 = 7.5"	S = 6 Pin	C = Side clamp
		040 = 4"	110 = 110 mm	040 = 4"	080 = 8"	B = Single band	(available only w/ steel body)
		050 = 5"	140 = 140 mm	045 = 4.5"	XXX = Length	D = Double band	I = Interchangeable nose w/ quick-release pins
		060 = 6"	143 = 143 mm	050 = 5"	12" Max for aluminum		
		080 = 8"		055 = 5.5"	24" Max for steel		
To be used with "BW" series Pneumatic Balancers. Consult factory for applications with rolls prone to telescoping.							
				060 = 6"			
				065 = 6.5"			

Zimmerman Series Handling Devices

Custom devices

Ingersoll Rand is a world leader in the manufacture of ergonomic, in-process, manual and powered custom material handling systems. We offer a complete range of handling devices, from the simplest to the most complex custom device. We specialize in providing turnkey solutions utilizing our complete line of standard and custom products to create a combination that empowers individuals to work more comfortably and effectively.



Motor vehicle

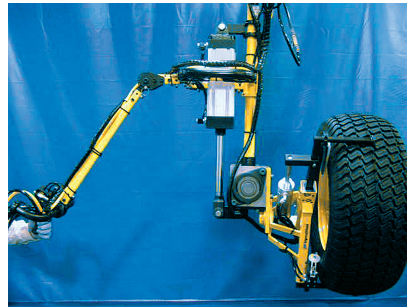

Agricultural equipment



Furniture / household

<p>CLAMP</p> <p>Cheese — food processing</p>	<p>HOOK / TRAP</p> <p>Gaming table</p>	<p>VACUUM</p> <p>Box — general industry</p>	<p>PROBE</p> <p>Steel roll</p>
<p>Box — general industry</p>	<p>Beverage handling</p>	<p>Toilet tank</p>	<p>Ceramic steel funnel</p>
<p>Floor scrubber</p>	<p>Vehicle transmission</p>	<p>Glass</p>	<p>HVAC — copper coil</p>

Contact factory for thousands more application photos and videos. E-mail requests to asbu_proposal@irco.com.

Zimmerman Series Torque Tubes

The Ingersoll Rand Torque Tube

ADVANTAGE

- ▶ **Guided lifting** — Cylinder guides up/down motion, preventing load from swinging
- ▶ **Effortless vertical travel** — Super linear bearings provide smooth, effortless motion
- ▶ **Versatility** — Four models available for both torque reaction and lifting applications
- ▶ **Torque reaction** — 4 Delrin® wheels for torque reaction and side loading in all four directions
- ▶ **Adaptable** — Universal mounting plate for bolt-on integration of tool holders and handling devices

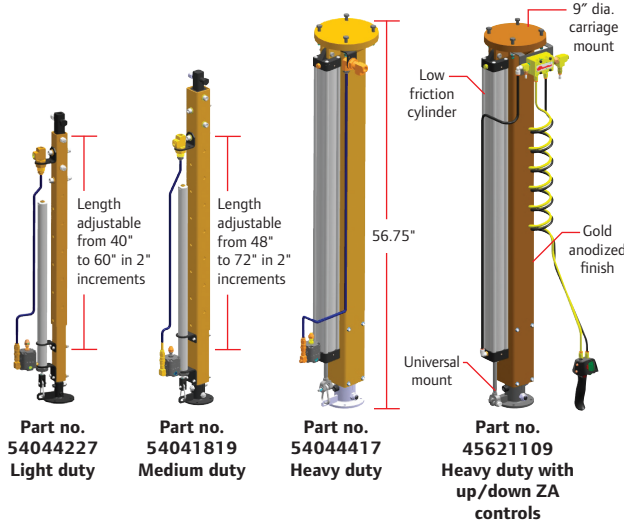

Torque tube with integrated vacuum handling device

Torque tube models

Part No.	Description	Torque Capacity ft-lbs (Nm)	Lift Capacity		Weight lb (kg)	Travel in (mm)	Control
			lbs @ 100 psi	kg @ 7 kg/cm ²			
54044227	IRZ-TT-100	74 (100)	60	27	40 (18)	20 (508)	BA regulator
54041819	IRZ-TT-250	184 (250)	60	27	50 (23)	24 (610)	BA regulator
54044417 ¹	IRZ-TT-500	368 (500)	100	45	75 (34)	36 (914)	BA regulator
45621109 ^{1,2}	IRZ-ZA-500	368 (500)	150	68	80 (36)	36 (914)	ZA Up/Down

Optional cylinder air supply

Part No.	Description
90050	Cylinder air supply package

Includes regulator assembly and all required hose fittings to supply cylinder.

¹ Carriage mount option only.
² Accommodates offset loads to 24" (609 mm). Consult factory for special applications.

Suspension options:

Suspension kits – single and dual trolleys

Rail Profile	Part No.	"A" Dimension in (mm)	Weight lb (kg)
SINGLE TROLLEY – USE FOR 80 NM OR LESS APPLICATIONS			
ZRA2	16610	4.75 (120)	4.50 (2)
ZRAS2/3	16600	4.75 (120)	4.50 (2)
KBK-II/IIL	16615	4.75 (120)	4.50 (2)
ETA-8	16635	4.75 (120)	4.50 (2)
T-Rail	16620	3 (76.2)	15 (6.8)
DUAL TROLLEY – UP TO 150 NM APPLICATIONS			
ZRAT	16755	6.48 (165.0)	10.50 (4.76)
ZRA1	16705	6.13 (156.0)	10.50 (4.76)
ZRA2	16710	6.76 (172.0)	10.50 (4.76)
ZRAS2/3	16700	6.76 (172.0)	10.50 (4.76)
KBK-I	16725	6.13 (156.0)	10.50 (4.76)
KBK-II/IIL	16715	6.76 (172.0)	10.50 (4.76)
ETA-4	16744	6.13 (156.0)	10.50 (4.76)
ETA-8	16735	6.76 (172.0)	10.50 (4.76)

Note: For use on torque tube part no. 54044227 and 54041819.

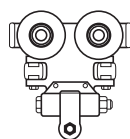

Suspension kit, Single trolley
Use for 80 Nm or less

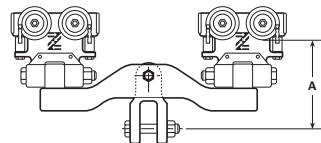

Suspension kit, Dual trolley
Use for 150 Nm or less

Carriages

Description	Part No.
Carriage — basic, no trolleys	40710
Carriage assembly — T-rail / I-beam	40709
Carriage assembly — ZRA2 (reaction trolley)	30028-1
Carriage assembly — ZRS2 / ZRS3	30028-2
Carriage assembly — ZRA1	30028-3
Carriage assembly — ETA-8 (reaction trolley)	30028-4
Carriage assembly — KBK2	30028-5

Note: For use on part no. 54044417 and 45621109
 Lightweight ALMAG casting. Basic carriage weighs 60.0 lb (27.3 kg)
 Each carriage ass'y drawing has info for both high and low profile assemblies.

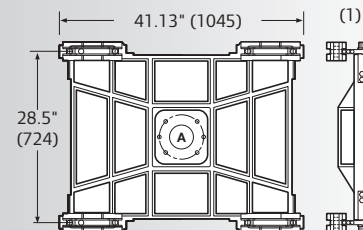

A = 1/2" bolts (6), Holes on a 7.5" bolt circle as shown
 9/16 drill thru on a 7.5" bolt circle.

Standard tool holders available.
 Refer to assembly catalog: IRPS-1007-052

Global Solution Center Locations

China

Ingersoll Rand Company
335 Lv Chun Road
Minhang Industrial Zone
Shanghai 200245, P.R.C.
Telephone: +86.21.6463.8018

France

Ingersoll Rand Company
70 rue Jacquard
77400 Lagny sur Marne, France
Telephone: +33 1 64 76 00 00

India

Ingersoll Rand Industrial Products Pvt. Ltd.
37-A, Site 4, Sahibabad Industrial Area
Ghaziabad-201010, India
Telephone: +91-120-4389400 / 4289400

Mexico

Ingersoll Rand, S.A. de C.V.
Boulevard Centro Industrial No. 11
Industrial Puente de Vigas
54070 Tlalnepantla, Mexico
Telephone: +52 (55) 50056600

North America

Ingersoll Rand Company
1872 Enterprise Drive
Rochester Hills, MI 48309, USA
Telephone: +1 (248) 293-5700

Russia

ZAO Ingersoll Rand CIS (1043)
Pavlovo Factory Ul. Chapaeva 43
Nizhegorodskaya Oblast
Pavlovo 606108
Russian Federation
Telephone: +7 (83171) 3 22 22

Ingersoll Rand is a proud member
of the following organizations:





Ingersoll Rand (NYSE:IR) advances the quality of life by creating and sustaining safe, comfortable and efficient environments. Our people and our family of brands—including Club Car®, Ingersoll Rand®, Schlage®, Thermo King® and Trane®—work together to enhance the quality and comfort of air in homes and buildings; transport and protect food and perishables; secure homes and commercial properties; and increase industrial productivity and efficiency. Ingersoll Rand products range from complete compressed air systems, tools and material and fluid handling systems. The diverse and innovative products, services and solutions enhance our customers' energy efficiency, productivity and operations. Ingersoll Rand is a \$14 billion global business committed to a world of sustainable progress and enduring results. For more information, visit ingersollrand.com or ingersollrandproducts.com.



www.ingersollrandproducts.com

Distributed by:

Ingersoll Rand, IR and the IR logo are trademarks of Ingersoll Rand, its subsidiaries and/or affiliates. All other trademarks are the property of their respective owners.
WARNING: This equipment is not designed for transporting people or lifting loads above people. It is the user's responsibility to determine the suitability of this product for any particular use and to check compliance with applicable regulations. Before installation, see maintenance and operations manual for additional warnings and precautions.

Nothing contained on these pages is intended to extend any warranty or representation, expressed or implied, regarding the product described herein. Any such warranties or other terms and conditions of sale of products shall be in accordance with Ingersoll Rand's standard terms and conditions of sale for such products, which are available upon request.

Product improvement is a continuing goal at Ingersoll Rand. Designs and specifications are subject to change without notice or obligation.